

**Series 2, Built-in fridge-freezer with freezer at bottom, 177.2 x 54.1 cm, flat hinge
KIN86NFE0G**



Optional accessories

- KSZB6R00 Bottle Rack
- KSZGGM00 Butter box

The spacious built-in fridge-freezer combination with NoFrost provides optimal food storage and ice formation is no longer an issue.

- **MultiBox XXL:** extra-large drawer for your fruit and vegetables.
- **NoFrost:** never defrost again, thanks to perfect protection from ice formation - that saves time and effort.
- **Eco Airflow:** maintains optimal air circulation and a constant temperature level throughout the cooling area.
- **LED lights bring a completely new lighting concept to fridges**
- **Automatic Super Freezing function: optimal for freezing smaller food load faster whilst protecting your frozen items from defrosting, thanks to the detection of temperature increase and the automatic decrease of temperature**

Technical Data

Energy Efficiency Class:	E
Average annual energy consumption in kilowatt hour per year (kWh/a):	234 kWh/annum
Sum of volume of frozen compartments:	76 l
Sum of volume of chill compartments:	184 l
Airborne acoustical noise emissions :	35 dB(A) re 1 pW
Airborne acoustical noise emission class:	B
Installation type:	Built-in
Door panel options:	Not possible
Height:	1772 mm
Width of the appliance:	541 mm
Depth of the product:	548 mm
Min. required niche size for installation (HxWxD): 1775.0 x 560 x 550 mm	
Net weight:	52.6 kg
Fuse protection:	10 A
Door hinge:	Right reversible
Voltage:	220-240 V
Frequency:	50 Hz
Length of electrical supply cord:	230.0 cm
Number of compressors:	1
Number of independent cooling systems:	1
Interior ventilator:	No
Reversible Door Hinge:	Yes
Number of Adjustable Shelves in fridge compartment (Stck):	3
Shelves for Bottles:	No
Frost free system:	Freezer
Installation type:	N/A



Series 2, Built-in fridge-freezer with freezer at bottom, 177.2 x 54.1 cm, flat hinge KIN86NFE0G

Additional features
Design features
Dimension and installation

The spacious built-in fridge-freezer combination with NoFrost provides optimal food storage and ice formation is no longer an issue.

Performance and Consumption

- EU19_EEK_D: E
- Total Volume : 260 l
- Annual Energy Consumption: 234 kWh/a
- EU19_Fast freezer facility_D
- Noise Level : 35 dB , EU19_Noise emission class_D: B

Functions

- Bright interior LED fridge light in fridge section

Design features

- LED electronic control
- Super Cooling: No
- Automatic defrost fridge
- Optical and accoustical

Design features

- Net Fridge Volume : 184 l
- 4 safety glass shelves of which 3 are height adjustable
- Door shelves in fridge door: 1 large and 2 small.

Freshness System

- 1 MultiBox - Transparent drawer with a rippled bottom, ideal for storing fruits and vegetables.

Food freshness system

- Net Freezer Volume : 76 l
- Freezing capacity 24h : 4 kg
- Temperature rise time : EU19_Temperature rise time_D: 10 H
- NO_FROST_NEU_BL, never have to defrost ever again
- SuperFreeze function with automatic deactivation
- 3 freezer drawers

Dimension and installation

- Dimensions: 177.2 cm H x 54.1 cm W x 54.8 cm D
- Niche Dimensions: 177.5 cm H x 56 cm W x 55 cm D

Key features - Fridge section

- Right hinged door, door reversible
- 220 - 240 V
- Length of power cord: 230 cm
- Height adjustable front feet
- Climate Class: SN-ST

Country Specific Options

- Based on the results of the standard 24-hour test. Actual consumption depends on usage/position of the appliance.

Key features - Freezer section

- 3 x egg tray, 1 x ice cube tray

**Series 2, Built-in fridge-freezer with freezer at bottom, 177.2 x 54.1 cm, flat hinge
KIN86NFE0G**

measurements in mm

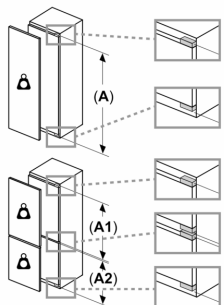
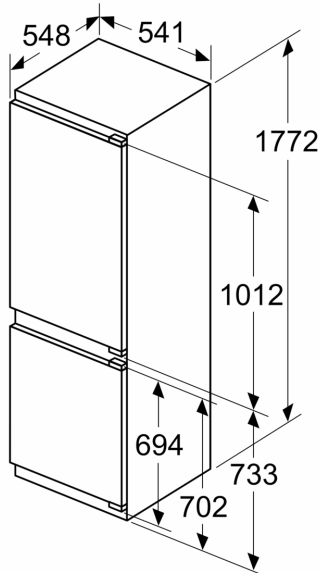

Maximal permissible weight of the unit fronts

Fitted unit fronts that exceed the permissible weight may cause damage and result in functional impairment of the hinges

Δ Weight

A: Appliance door height including hinges in mm

B: Undamped hinge, unit front in kg

C: Damped hinge, unit front in kg

D: Additional possible load in kg with heavy load kit

A	B	C	D
1500-1750	22	22	
720-1400	19	19	B+5 / C+5
A1	15	19	
A2	15	19	

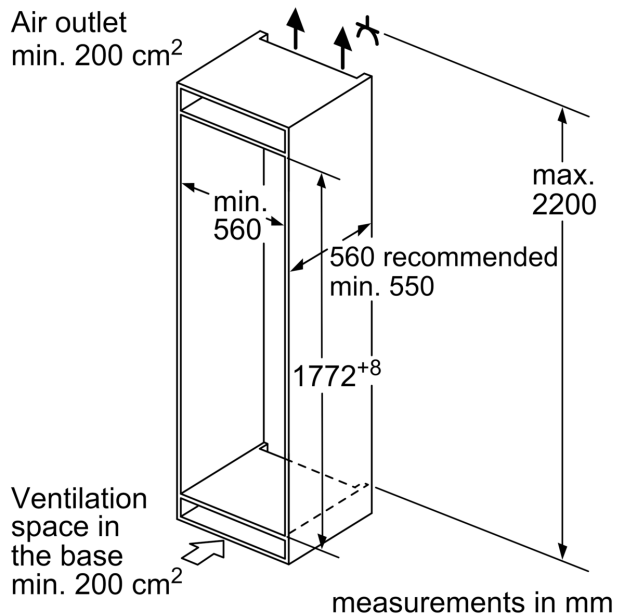

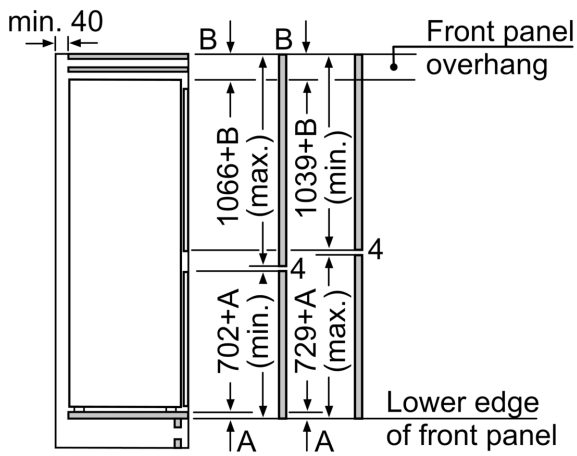

The specified unit door dimensions are valid for a door gap of 4 mm.
 measurements in mm

measurements in mm
 Recommended gap dimensions for flat hinges

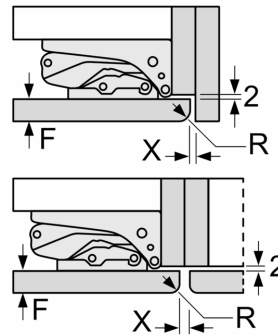

F	R	X
16-19	0-3	2.5
20	0-1	3
	2-3	2.5
21	0-1	3
	2-3	2.5
22	0	4
	1	3.5
	2-3	3

The gap dimensions recommended in the table must be adhered to in order to ensure that appliance doors do not collide with anything when they are opened, and to avoid causing damage to kitchen units.