

# HOMEBASE

## ODETTE BISTRO SET

---

INSTRUCTION MANUAL

---



IMPORTANT: Please read these instructions before using the product and retain for future use.

HHGL Limited, MK9 1BA  
HHGL (ROI) Limited, D02 X576

V1\_2023

## SAFETY & CARE ADVICE

Please read these instructions fully before starting assembly.

- Check you have all the components and tools listed before you start assembly.
- Remove all fitting from the plastic bags and separate them into their groups.
- Keep children and animals away from the work area; small parts could pose a choking hazard if swallowed.
- Make sure you have enough space to lay out the parts before starting.
- Do not stand or put weight on the component parts or the product, as this could cause damage.
- Assemble the item as close to its final position as possible.
- Assemble on a soft, level surface to avoid damaging the unit or your floor.
- Parts of the assembly will be easier with two people.
- We do not recommend the use of power drills/drivers for inserting screws, as this could damage the unit.
- Only use hand screwdrivers.
- Dispose of all packaging carefully and responsibly.
- Domestic use only.
- Chair maximum safe weight of use is 110kg.

## CARE AND MAINTENANCE

- We recommend that you cover your garden furniture when it's not in use, and that it is stored in a garage or shed throughout the winter months.
- Please ensure the furniture is dry before storing.
- Only clean using a damp cloth and mild detergent; do not use bleach or abrasive cleaners.

## IMPORTANT INFORMATION

- Regularly check all the bolts, screws and fastenings are secure.
- Do not use this table unless all bolts and screws are firmly secure.
- This product should not be discarded with household waste. Take it to your local authority waste disposal centre.

## BEFORE ASSEMBLY

Please check you have all the components and fittings listed below. If you find any missing or damaged parts, please contact our customer services team on 0333 003 7084 between 09:00 & 18:00, or use the contact form on our website [www.homebase.co.uk](http://www.homebase.co.uk)

# ASSEMBLY INSTRUCTIONS - CHAIR

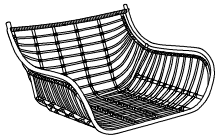

1

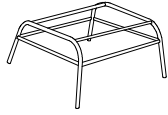





2

## Parts:

No.	Description	Qty
1	Lower seat	x 1
2	Chair base	x 1
3	Upper seat	x 1
4	Cushion	x 1

## Fittings:

No.	Description	Qty
A	M6 x 30mm Bolts 	x 7
B	Washer 	x 12
C	Allen Key 	x 1
D	M6 x 10mm Bolts 	x 4
E	M6 x 15mm Bolts 	x 1

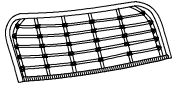

3



4

Connect the lower seat (1) and chair base (2) together by using bolts (A) and washers (B), as illustrated in step 1.

Attach the upper seat (3) to the lower seat (1) by using bolts (A) and washers (B), as illustrated in step 2.

Turn the chair to its upright position. Place the cushion (4) onto the seat. Secure the cushion to the chair by using the straps, as illustrated in step 3.

### Step 1

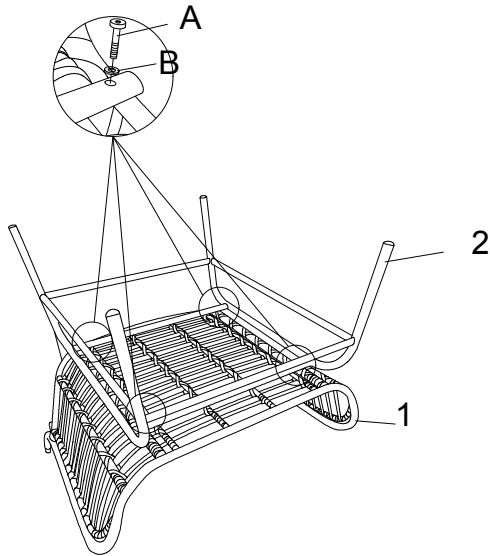

### Step 2

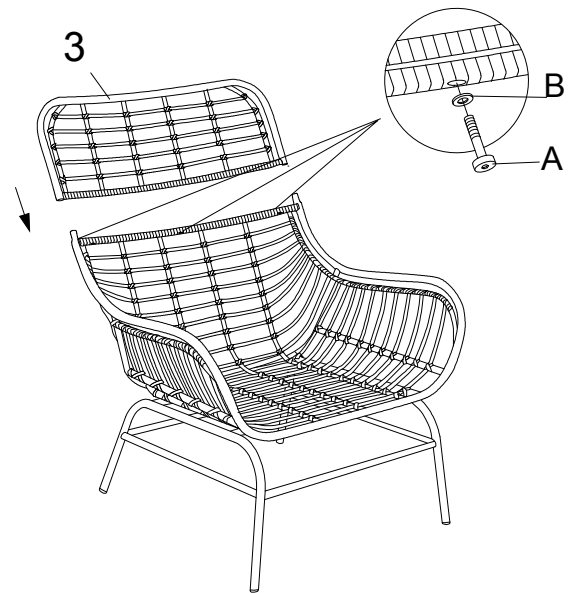

### Step 3

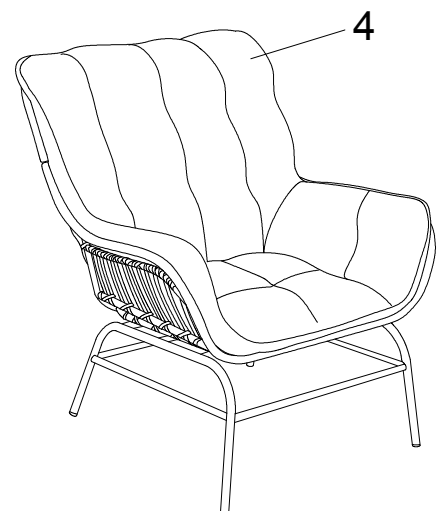

# ASSEMBLY INSTRUCTIONS - TABLE

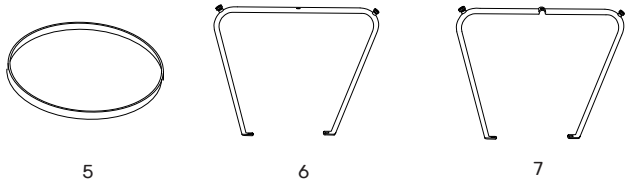

## Parts:

No.	Description	Qty
5	Table Top	x 1
6	Leg	x 1
7	Leg	x 1

Place the table top (5) onto a non-abrasive surface, such as a carpet, with its underside facing upwards.

Fasten the leg (6) to the table top (5) by using bolts (D) and washers (B), as illustrated in step 1.

Fasten another leg (7) to the table top (5) by using bolts (D) and washers (B), connect two legs by using bolts (E) and washers (B), as illustrated in step 2.

## Step 1

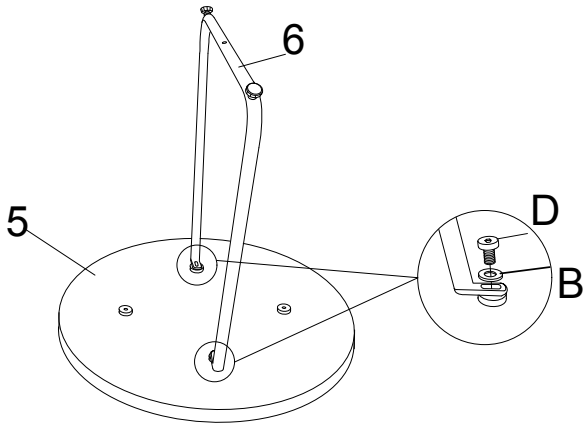

## Step 2

