

HOMEBASE

NIMBUS 6 BURNER GAS BBQ

INSTRUCTION MANUAL



IMPORTANT: Please read these instructions before using the product and retain for future use.

HHGL Limited, MK9 1BA
HHGL (ROI) Limited, D02 X576

V1_2023

GENERAL INFORMATION

Safety and Care Advice

IMPORTANT: Please read these instructions fully before starting assembly and using the appliance.

WARNING: Whilst every effort has been made in the manufacture of your barbecue to remove any sharp edges, care should be taken in handling to avoid any accidental injury.

- Use outdoors only.
- Do not use the barbecue or store gas bottles below ground level. LPG is heavier than air so, if a leak occurs, the gas will collect at a low level and could ignite in the presence of a flame or spark.
- For use with LPG bottled gas only. A suitable regulator must be used for butane, propane or mixes.
- Remove plastic wrap from any part before lighting.
- Do not use within 1 metre of any flammable structure or surface. Do not use under any combustible surface.
- LPG cylinders should never be placed directly underneath the barbecue.
- LPG cylinders should never be stored or used on their side in the horizontal position. A leak would be very serious and liquid could enter the gas line with serious result.
- Never store gas bottles indoors.
- Do not move the appliance during use.
- Open the barbecue hood before lighting.
- Do not move the barbecue until it has completely cooled after use.
- This barbecue must not be left unattended when lit.
- The hood handle can become very hot. Grip only the centre of the handle. Always use oven gloves when cooking or carrying out any adjustments to the barbecue.
- Use purpose-designed barbecue tools with long and heat-resistant handles.
- Use caution when opening the hood, as hot steam inside is released upon opening.
- **WARNING:** Accessible parts may be very hot. Keep young children and pets away.
- Turn off the gas supply at the gas cylinder after use.
- Never cover a barbecue until it has completely cooled.
- Use this barbecue only on a stable and flat surface.
- Before using this barbecue, perform a leak test. This is the only safe and sure way to detect any gas leaking from joints and connections after assembly.
- Leak test annually, and whenever the gas bottle is removed or replaced.
- Do not store flammable materials near this barbecue.
- Do not use aerosols near this barbecue.
- Failure to follow the manual's instructions could result in serious injury or damage.
- Do not modify the appliance. Modification of this barbecue may be dangerous, is not permitted and will nullify any warranty.
- This appliance must be kept away from flammable materials during use.
- All the parts sealed by the manufacturer or his agent shall not be manipulated by the user.
- If you have any queries regarding these instructions, contact your local store.

Assembly

- Assembly time: approx. 45-60 minutes.
- While every effort has been made in the manufacture of your barbecue to remove any sharp edges, you should handle all components with care to avoid accidental injury.
- Dispose of all packaging carefully and keep out of the reach of children.
- Please read the section on barbecue safety prior to using your barbecue.

GAS AND REGULATOR

This barbecue can use either propane or butane or propane/butane mixed LPG (liquid petroleum gas) bottled gas. Propane bottles will supply gas all year round, even on cold winter days. Butane bottles will supply sufficient gas in summer, but it may affect the performance of the barbecue and restrict the heat output available from the burners, particularly once the gas temperature starts to fall below +10°C.

A spanner may be required to change gas bottles.

- The hose should hang freely with no bends, twists, tension, folds, or kinks that could obstruct free flow of gas. Always inspect the hose for cuts, cracks, or excessive wear before use.
- Apart from the connection point, no part of the hose should touch any hot barbecue parts. If the hose shows any sign of damage, it must be replaced with a hose suitable for use with LPG, which meets the national standards for the country of use.
- A suitable hose must comply with EN16436-1, and the length should not exceed 1.5 metres.

For optimal performance, we suggest using a 5-15kg gas bottle. The maximum dimension of the gas bottle is dia. 31.5cm and height 58cm.

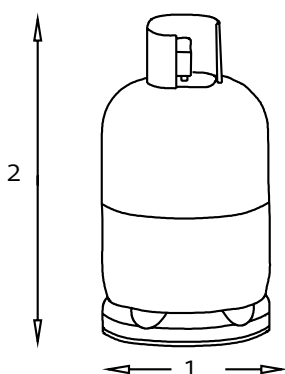

Key

1= maximum diameter

2= maximum height

Never mount the gas bottle under the barbecue on the base shelf, as this could result in serious injury to the user, other people and/or property.

Always place the gas bottle at the side of the appliance. The gas bottle should be sited as far away from the appliance as possible without straining the hose.

This appliance is only suitable for use with low-pressure butane or propane gas, and fitted with the appropriate low-pressure regulator via a flexible hose. The hose should be secured to the regulator and the appliance with hose clips/nut. This barbecue is set to operate a 28-30mbar regulator with butane gas, or a 37mbar regulator with propane gas. Use a suitable regulator certified to EN16129. Please consult your LPG dealer for information regarding a suitable regulator for the gas cylinder.

INSTALLATION

Selecting a Location

This barbecue is for outdoor use only and should be placed in a well-ventilated area, and on a safe and even surface. Never place your barbecue below ground level. Take care to ensure that the barbecue is used on an incombustible floor. The sides of the barbecue should NEVER be closer than 1 metre from any combustible surface, including trees and fences; and make sure that there are no heat sources near the barbecue (cigarettes, open flames, sparks, etc.). Keep this barbecue away from any flammable materials!

Precautions

Do not obstruct any ventilation openings in the barbecue body. Position the gas bottle on level ground next to the barbecue and safely away from any source of heat. Should you need to install or change the gas bottle, confirm that the barbecue is switched off and that there are no sources of ignition (cigarettes, open flames, sparks, etc.) near before proceeding.

Fixing a Regulator to the Gas Bottle

Confirm all barbecue control knobs are in the 'OFF' position. Connect the regulator to the gas bottle according to your regulator and bottle dealer's instructions.

Leak Testing (always perform a leak test in a well-ventilated area)

Confirm all control knobs are in the 'OFF' position. Turn the gas on/open the gas control valve on the gas bottle or regulator. Check for leaks by brushing a solution of 1/2 water and 1/2 liquid detergent/soap over all the gas system joints, including gas bottle valve connections, hose connections, and regulator connections. NEVER USE AN OPEN FLAME to test for leaks at any time. If bubbles form over any of the joints, there is a leak.

Turn off the gas supply at the gas bottle. Retighten all joints. Repeat the test. If bubbles form again, do not use the barbecue and contact your local store for assistance. Always wipe the mixed leak-testing solution from all joints and connections afterwards.

OPERATION

Warning

- Before proceeding, make certain that you understand the IMPORTANT INFORMATION section of this manual.
- Your barbecue is not designed to be used with more than 50% of the cooking area as a solid plate - this includes baking dishes. Full coverage will cause excessive build up of heat and damage the barbecue. This is not covered by the warranty.

Preparation before Cooking

To prevent foods from sticking to the cooking surface, please use a long-handled brush to apply a light coat of cooking or vegetable oil before each barbecuing session. (Note: When cooking for the first time, paint colours may change slightly as a result. This is normal and should be expected.) During use, the protective coating may come off the cooking surface. This is normal and is not harmful. Line the drip pan with aluminium foil. This will make cleaning up easy.

Lighting the Main Burner

- Open the barbecue hood.
- Ensure all knobs are in the 'OFF' position. Open the gas control valve on the gas bottle or regulator.
- From the 'OFF' position, push in and turn the ignition sign burner control knob anti-clockwise until you feel resistance and pause for 4 seconds. Then continue turning the control knob until a click is heard and the burner is lit.
- If the burner fails to ignite after the above procedure, turn all the knobs to the 'OFF' position and close the gas valve on the gas bottle. Wait 5 minutes and then repeat the above steps. If the barbecue still fails to light, please refer to the manual ignition instruction in the section to the right.

- After the ignition sign # burner has been lit, push in and turn the left hand and right hand burners for extended cooking area.
- Always light the ignition sign # burner first, before the next burner on the left or right.
- Failure to follow this lighting sequence could result in a hazardous situation occurring.
- After ignition, the burner should be burned at the high position for 3-5 minutes in order to preheat the barbecue. This process should be done before every cooking session. The hood (where applicable) should be open during preheating.
- After completion of preheating, the burner should normally be turned down to a lower position for best cooking results.

Manual Ignition Instruction for Main Burner

- Insert lit match through the match-lighting hole at the side or bottom of the barbecue body.
- Push in and turn the ignition sign # burner control knob anti-clockwise to the 'MAX.' position, the burner should ignite.
- After the ignition sign # burner is lit, push and turn the left hand or right hand control knob to the 'MAX.' position, the left hand or right hand burner should ignite automatically.
- Repeat the same procedure to light the next burner on the left or right.
- If the burner fails to ignite, contact your local store for assistance.
- After ignition, the burner should be burned at the 'MAX.' position for 3-5 minutes in order to preheat the barbecue. This process should be done before every cooking session. The hood (where applicable) should be open during preheating.
- After completion of preheating, the burner should normally be turned down to a lower position for best cooking results.

Lighting the Side Burner

- Open the side burner hood.
- Keep the side burner free.
- Set the control knob to 'OFF' and turn on the gas supply.
- Push in and turn the control knob anti-clockwise until it reaches the 'MAX.' position.
- Press the electronic ignition button and hold for 5 seconds to light the burner.
- If the burner fails to ignite after the above procedure, turn the knob to the 'OFF' position and close the gas valve. Wait 5 minutes and then repeat the above steps. If the barbecue still fails to light, please refer to the manual ignition instruction in the section below.

Manual Ignition Instruction for Side Burner

- Set the control knob to the 'OFF' position.
- Apply a lit match on the gap to burner ports.
- Push and turn the control knob anti-clockwise to the 'MAX.' position and the burner should ignite. If the burner fails to ignite, contact your local store for assistance.

Grill Cooking

The burners heat up the flame tamer underneath the grill, which, in turn, heats the food on the grill. The natural food juices produced during cooking fall onto the hot flame tamer below and vaporise. The subsequent rising smoke bastes the food, imparting that unique barbecued flavour.

Warming Rack

Warming racks are a convenient way to keep cooked food warm or to warm items, such as bread rolls. It is advisable to place food (particularly fatty foods) at the front of the warming rack to avoid the possibility of juices and fat running down the back of your barbecue. Always check that your warming rack is properly fitted before use.

Flare-up Control *Very Important Notice*

Flare-ups occur when meat is barbecued and its fat and juices fall upon the hot flame tamer. Smoke of course helps give food its barbecued flavour, but it is best to avoid excessive flare-up to prevent food becoming burned. To control flare-ups, it is ABSOLUTELY ESSENTIAL to trim away excess fat from meat and poultry before grilling; use cooking sauces and marinades sparingly, and try to avoid very cheap cuts of meat or meat products, as these tend to have a high fat and water content. Also, the burners should always be placed on the 'LOW' setting during cooking.

When flare-ups do occur, they can usually be extinguished by applying baking soda or salt directly onto the flame tamer. Always protect your hands when handling anything near the cooking surface of the barbecue and take care to protect yourself from the flames. If a fat fire occurs, please see the instructions given to the right.

Fat Fires

Empty and clean the drip tray of food debris after each cooking session. If the barbecue is to be used for large gatherings, it will be necessary to turn off and cool the barbecue every two hours, to remove food debris from the drip tray and clean it out. The time between cleaning may need to be reduced if very fatty foods or cheap meat products are being cooked. Failure to do this may result in a fat fire, which may cause injury and could seriously damage the barbecue.

In the Event of a Fat Fire

If safe to do so, turn all control knobs to the 'OFF' position. Turn off the gas supply at the gas bottle.

Keep everyone at a safe distance from the barbecue and wait until the fire has burnt out.

Do not close the hood or lid of the barbecue.

NEVER DOUSE A BARBECUE WITH WATER. IF AN EXTINGUISHER IS USED, IT SHOULD BE A POWDER TYPE.

DO NOT REMOVE THE DRIP TRAY.

If the fire does not seem to be abating or appears to be worsening, contact your local Fire Brigade for assistance.

End of Cooking Session

After each cooking session, turn the barbecue burners to the 'HIGH' position and burn for 5 minutes. This procedure will burn off any cooking residue, thus making cleaning easier. Make sure the hood is open during this process.

Turning Off Your Barbecue

When you have finished using your barbecue, turn all the control valves fully clockwise to the 'OFF' position, then switch off the gas supply at the bottle.

CARE AND MAINTENANCE

Regularly clean your barbecue between uses and especially after extended periods of storage. Ensure the barbecue and its components are sufficiently cool before cleaning. Do not leave the barbecue exposed to outside weather conditions or stored in damp, moist areas.

- Never douse the barbecue with water when its surfaces are hot.
- Never handle hot parts with unprotected hands.

In order to extend the life and maintain the condition of your barbecue, we strongly recommend that the unit be covered when left outside for any length of time, especially during the winter months.

Even when your barbecue is covered for its protection, it must be inspected on a regular basis, as damp or condensation can form, which may result in damage to the barbecue. It may be necessary to dry the barbecue and the inside of the cover. It is possible for mould to grow on any fat remaining on parts of the barbecue. This should be cleaned off smooth surfaces with hot soapy water.

Regularly clean your barbecue between uses and especially after extended periods of storage. Ensure the barbecue and its components are sufficiently cool before cleaning. Do not leave the barbecue exposed to outside weather conditions or stored in damp, moist areas.

- Never douse the barbecue with water when its surfaces are hot.
- Never handle hot parts with unprotected hands.

In order to extend the life and maintain the condition of your barbecue, we strongly recommend that the unit be covered when left outside for any length of time, especially during the winter months.

Even when your barbecue is covered for its protection, it must be inspected on a regular basis, as damp or condensation can form, which may result in damage to the barbecue. It may be necessary to dry the barbecue and the inside of the cover. It is possible for mould to grow on any fat remaining on parts of the barbecue. This should be cleaned off smooth surfaces with hot soapy water.

Any rust that is found that does not come into contact with the food should be treated with a rust inhibitor and painted with barbecue paint or a heat-resistant paint. A chrome cleaner may be used on chrome parts if required. To prevent rusting, wipe chrome-plated parts with cooking oil after rinsing and drying.

Cooking Surfaces and Warming Rack

When the barbecue has cooled, clean with hot soapy water. To remove any food residue, use a mild cream cleaner on a non-abrasive pad. Do not use scouring pads or powders, as they can permanently damage the finish. Rinse well and dry thoroughly. Due to the weight of the cooking surfaces, we do not recommend cleaning in a dishwasher.

It is quite normal for surface rust to be present on the cooking surface. If rust appears between uses or in storage, clean with a soft bristle brush. Be careful not to damage the cooking surface, re-oil and cure.

Burner

Provided that they are operating correctly, in normal usage, burning off the residue after cooking will keep the burners clean.

The burners should be removed and cleaned annually, or whenever heavy build up is found, to ensure that there are no signs of blockage (debris, insects) in either the burner portholes or the primary air inlet of the burners. Use a pipe cleaner to clear obstructions. When refitting the burners, be careful to check that the neck of the burner fits over the valve outlet. It is quite normal for surface rust to be present on the burners. If rust appears between uses or in storage, clean with a soft bristle brush.

Flame Tamer

Remove any food residue from the flame tamer surface with a plastic or wooden scraper or nylon-bristled brush. Do not use a steel scraper or wire brush. Clean with hot soapy water and rinse well.

Drip Tray

After every use, empty and clean the drip tray of any fat or food particles, using a plastic or wooden scraper if necessary.

Failure to keep it clean means excessive build up can result in a fat fire. This can be hazardous and severely damage the barbecue. This is not a fault in the barbecue and is therefore not covered by the terms of the warranty. If required, the tray can be washed in hot soapy water.

Barbecue Body

Regularly remove excess grease or fat from the barbecue body using a cloth wrung out in hot soapy water and dry thoroughly. Excess fat and food debris can be removed from inside the body using a soft plastic or wooden scraper. It is not necessary to remove all the grease from the body. If you need to clean fully, use hot soapy water and a cloth, or nylon-bristled brush only. Do not use abrasives. Remove cooking surfaces and burners before full cleaning. Do not immerse the gas controls or manifold in water. Check burner operation after carefully refitting into body.

A stainless steel cleaner may be used on stainless steel parts if required.

Whenever a barbecue is being assembled for the first time, or its burners are being cleaned, make sure each gas valve tip goes into the burner venturi tube completely when fitting/re-fitting.

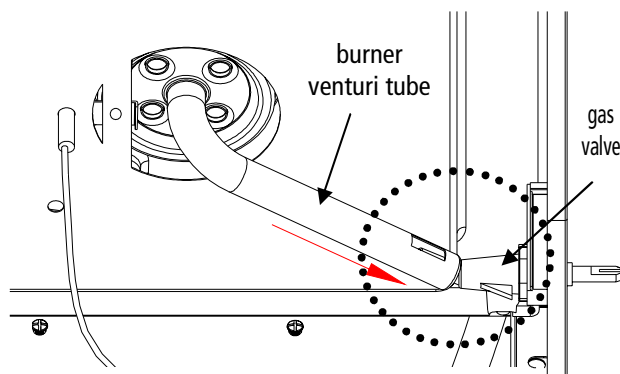

Barbecue Hood or Lid

Use a non-abrasive cloth or pad and clean with hot soapy water. Do not use scouring pads or powders, as they can permanently damage the finish.

Trolley

Wipe with a cloth wrung out in hot soapy water and dry.

Fixings

All screws and bolts, etc., should be checked and tightened on a regular basis.

Storage

Ensure the barbecue is properly cooled before covering or storing. Store your barbecue in a cool dry place. It must be inspected on a regular basis, as damp or condensation can form, which may result in damage to the barbecue. It may be necessary to dry the barbecue and the inside of the cover if used.

Mould can grow under these conditions and should be cleaned and treated, if required. Any rust that is found that does not come into contact with the food should be treated with a rust inhibitor and painted with barbecue paint or a heat-resistant paint.

Warming racks and cooking grills should be coated with cooking oil.

Cover the burners with aluminium foil in order to prevent insects or other debris from obstructing the burner holes. If the barbecue is to be stored indoors, the gas bottle must be disconnected and left outside. The gas bottle should always be stored outside, in a dry, well-ventilated area, away from any sources of heat or ignition. Do not let children tamper with the bottle.









When using the barbecue after extended periods of storage, follow the cleaning procedures.

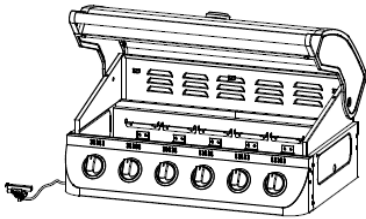

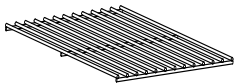

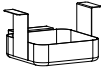
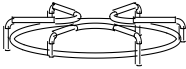
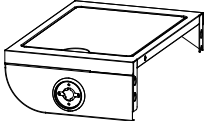
Carbon Monoxide Hazard

WARNING	CARBON MONOXIDE
	HAZARD Danger of carbon monoxide poisoning - NEVER light this product or let it smoulder or cool down in confined spaces.

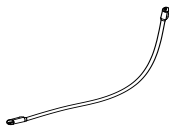
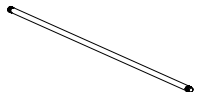
COMPONENT - PARTS

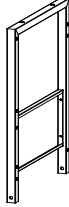
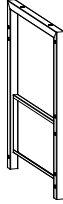

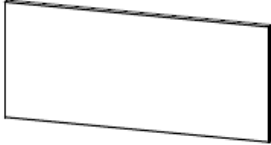
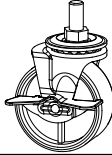

Please check you have all the components and fittings listed. If you find any missing or damaged parts, please contact our customer services team on 0333 003 7084 between 09:00 & 18:00, or use the contact form on our website www.homebase.co.uk

Part No.	Description	Illustration	Quantity
1	Grill assembly		1
2	Warming rack		1
3	Cooking grill		3
4	Heat tent		6
5	Grease cup		1
6	Side burner grate		1
7	Side burner assembly		1
8	Side burner knob		1
9	Side table assembly		1
10	Back brace		1
11	Side burner electrode wire		1
12	Axle		1

Part NO.	Description	Illustration	Quantity
13	Cart - Left side panel assembly		1
14	Cart - Right side panel assembly		1
15	Bottom shelf assembly		1
16	Lower - Front panel		1
17	Upper - Front panel		1
18	Castor		2
19	Wheel		2

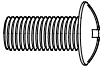
COMPONENT - FITTINGS

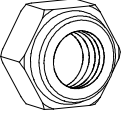
Please check you have all the components and fittings listed. If you find any missing or damaged parts, please contact our customer services team on 0333 003 7084 between 09:00 & 18:00, or use the contact form on our website www.homebase.co.uk

Part NO.	Description	Illustration	Quantity
A	M6*12mm Bolt		28
B	M6*35mm Bolt		4
C	Axle nut		2
D	Nut		2

ASSEMBLY INSTRUCTIONS

Remove all packaging.

Step 1

Put the Cart - Left side panel assembly 13 on the Bottom shelf assembly 15 using 12mm bolts A.

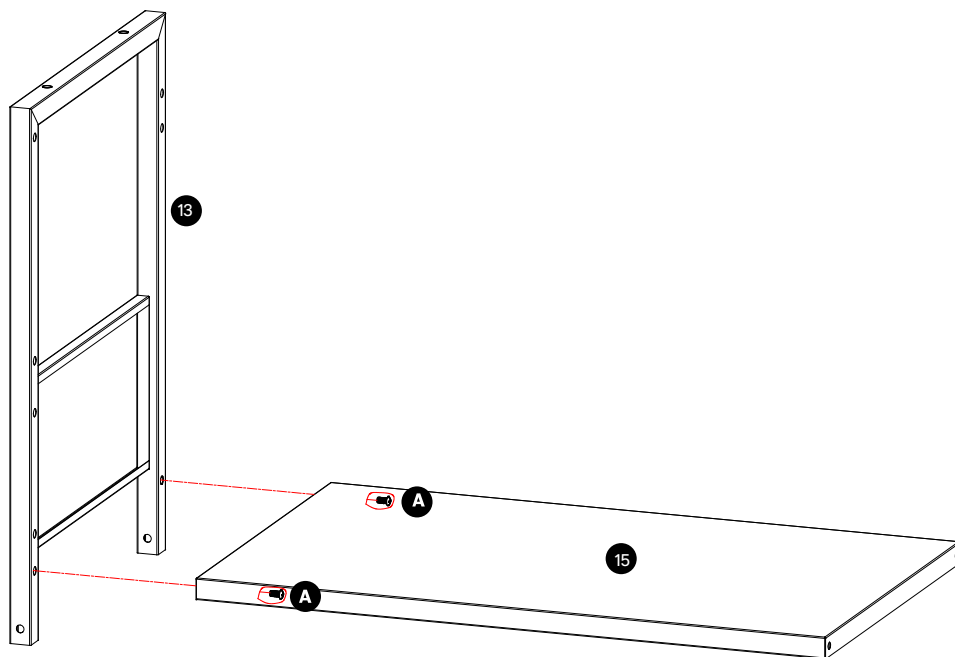

Step 2

Put the Cart - Right side panel assembly 14 on the Bottom shelf assembly 15 using 12mm bolts A.

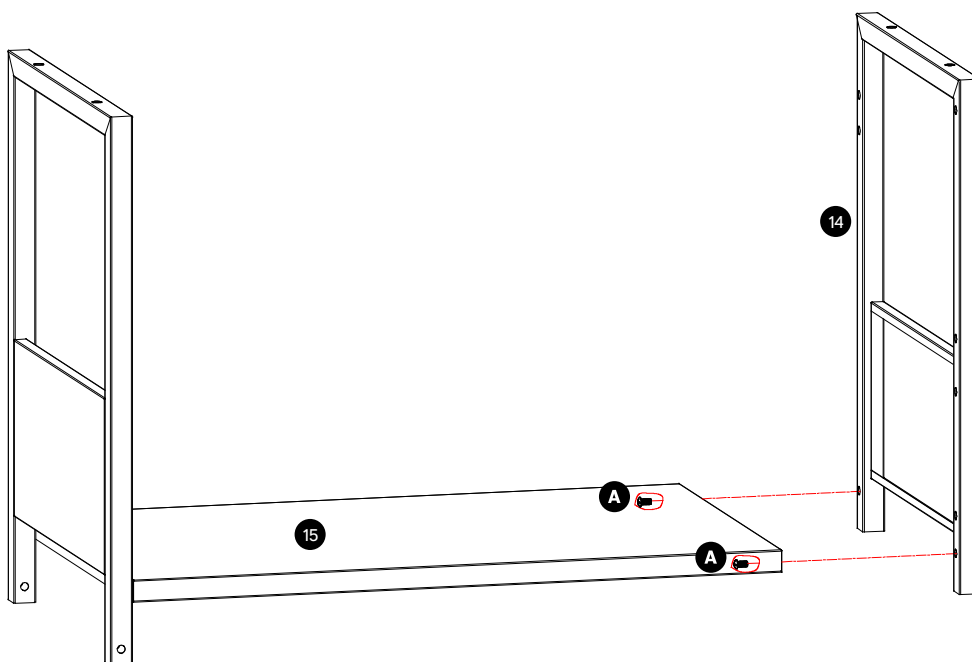

Step 3

Put the Lower - Front panel 16 and Upper - Front panel 17 between the Cart - Left side panel assembly 13 and the Cart - Right side panel assembly 14 using 12mm bolts A and nuts D.

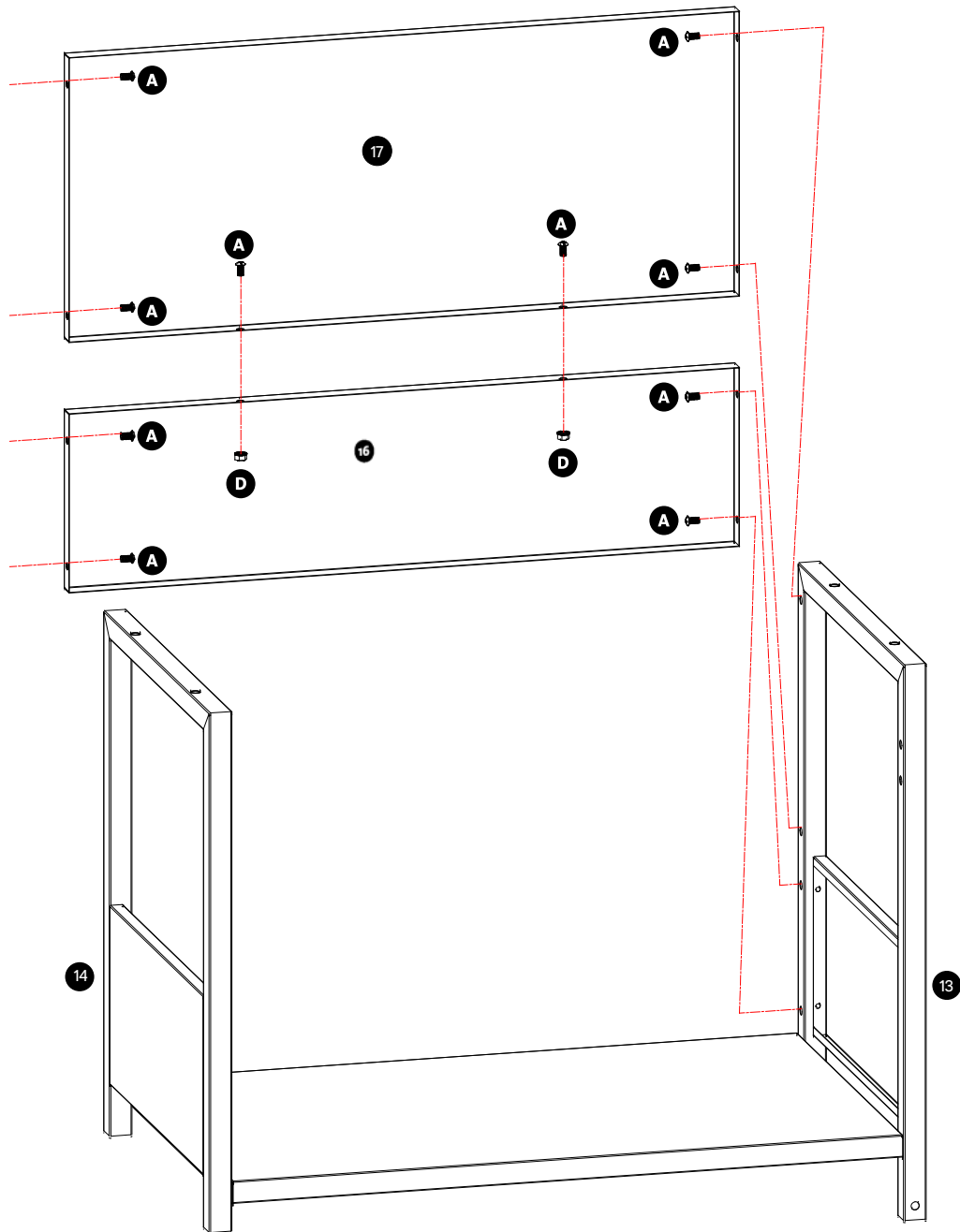

Step 4

Apply the wheels 19 to the front leg and the rear leg of the right cart assembly 13 using the axle 12. Then fix the axle 12 by the axle nuts C.

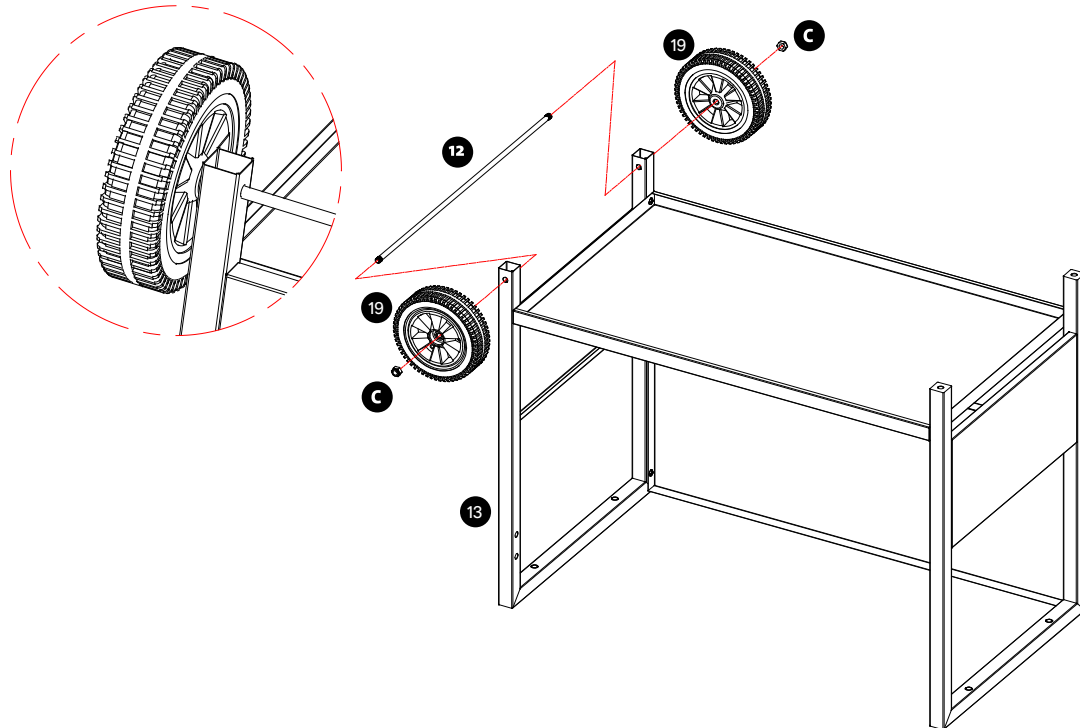

Step 5

Apply the Castor 18 to the leg of the Cart - Right side panel assembly 14.

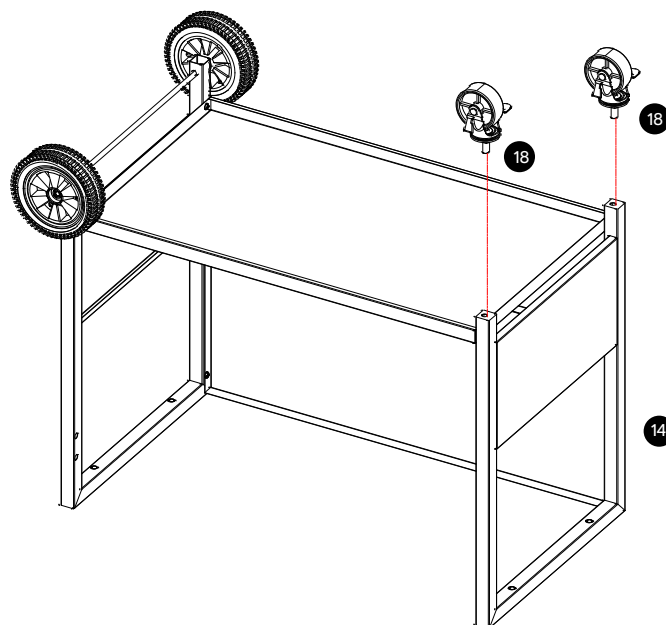

Step 6

Put the Back brace **10** between the Cart - Left side panel assembly **13** and the Cart - Right side panel assembly **14** using 12mm bolts **A**.

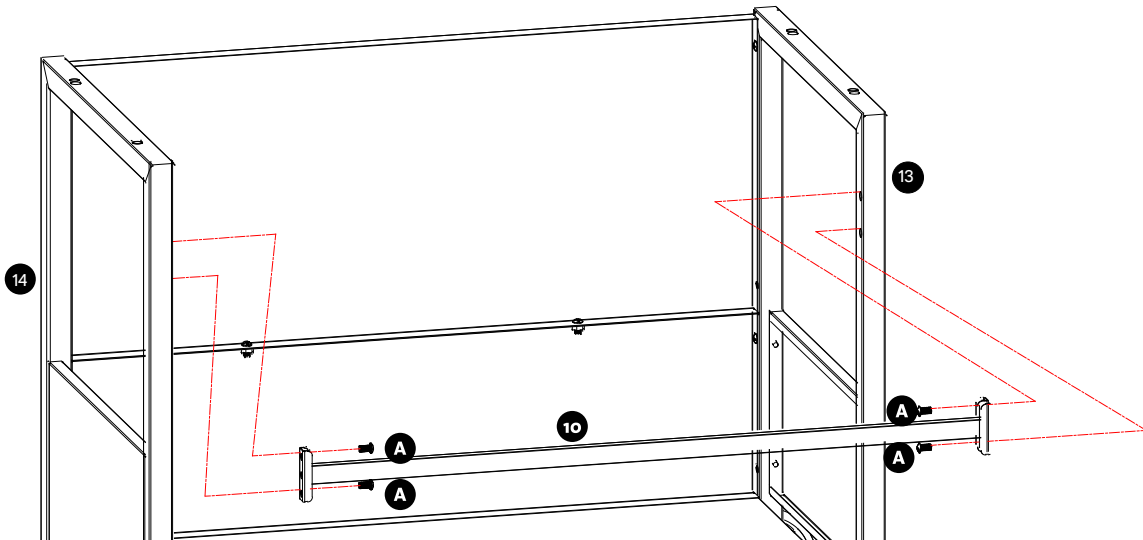

Step 7

Set the Grill assembly **1** on the assembled grill cart.

Secure the Grill assembly **1** with the Cart - Left side panel assembly **13** and the Cart - Right side panel assembly **14** using 35mm bolts **B**.

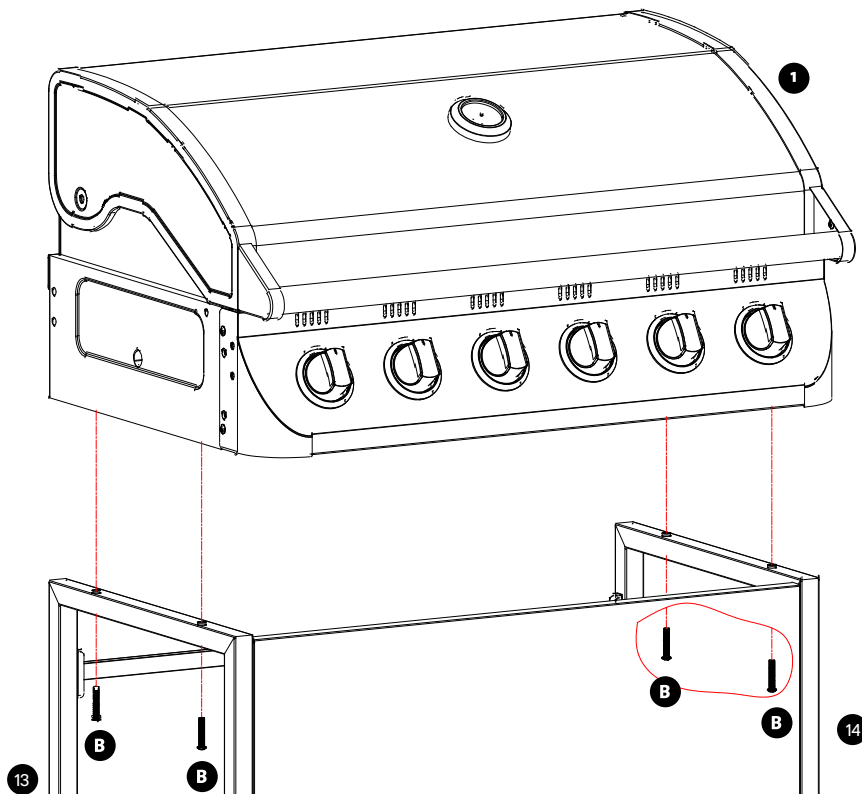

Step 8

Apply 8 of the 12mm bolts **A** to the left and right side of the Grill assembly **1**.
Have half of the bolt threads go into the bolt holes. Do not tighten the bolts at this stage.

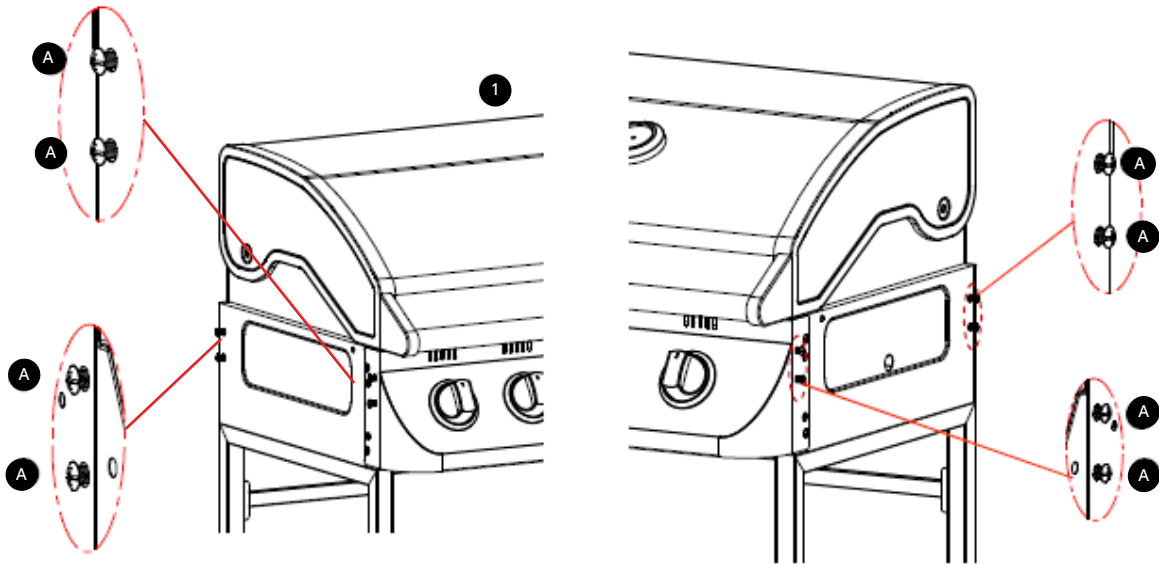

Step 9

Align the 12mm bolts **A** properly with the Side burner assembly **7**. Hang the Side burner assembly **7** to the Grill assembly **1**. Secure the bolts tightly by screwdriver after the alignment is done.

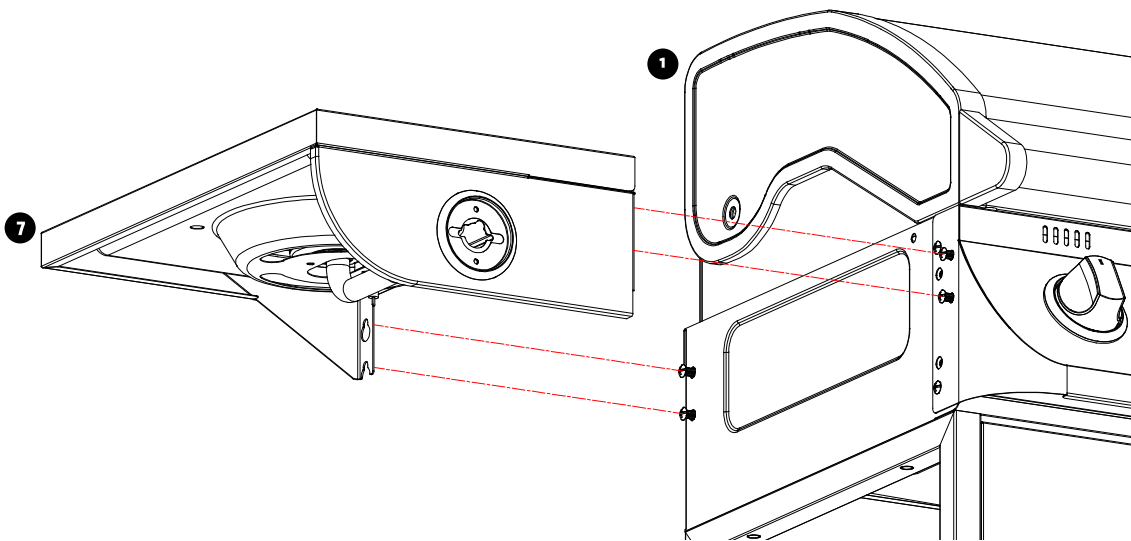

Step 10

Align the 12mm bolts **A** properly with the Side table assembly **9**. Hang the Side table assembly **9** to the Grill assembly **1**. Secure the bolts tightly by screwdriver after the alignment is done.

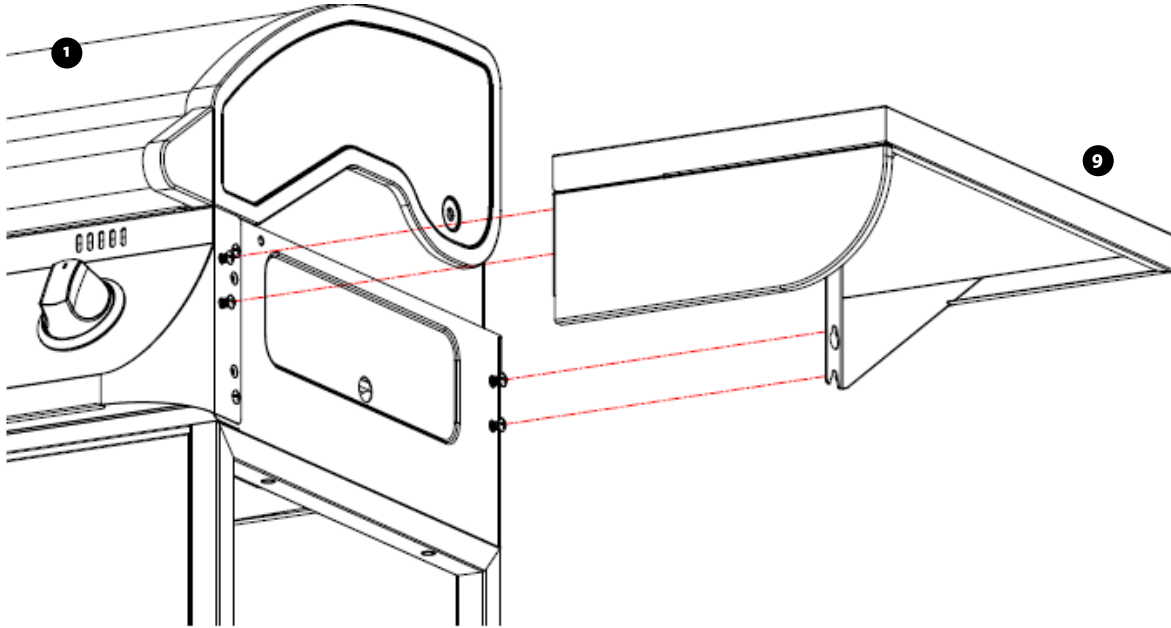

Step 11

Align and secure the Side burner assembly **7** and the Side table assembly **9** using the 12mm bolts **A**.

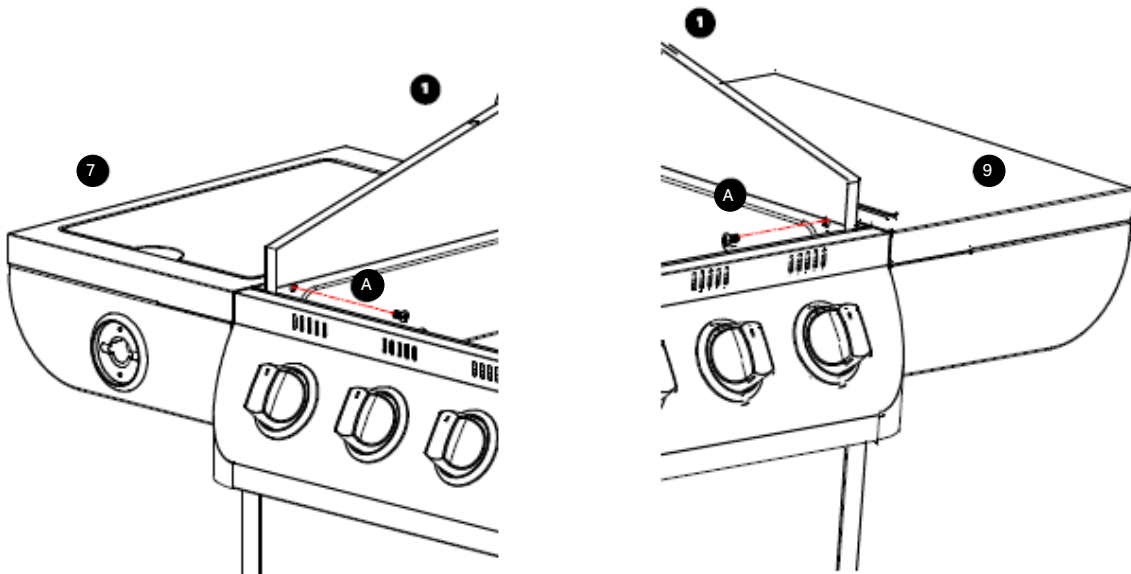

Step 12

A: Loosen the two pre-assembled screws between the side burner and the Side burner assembly ⑦.

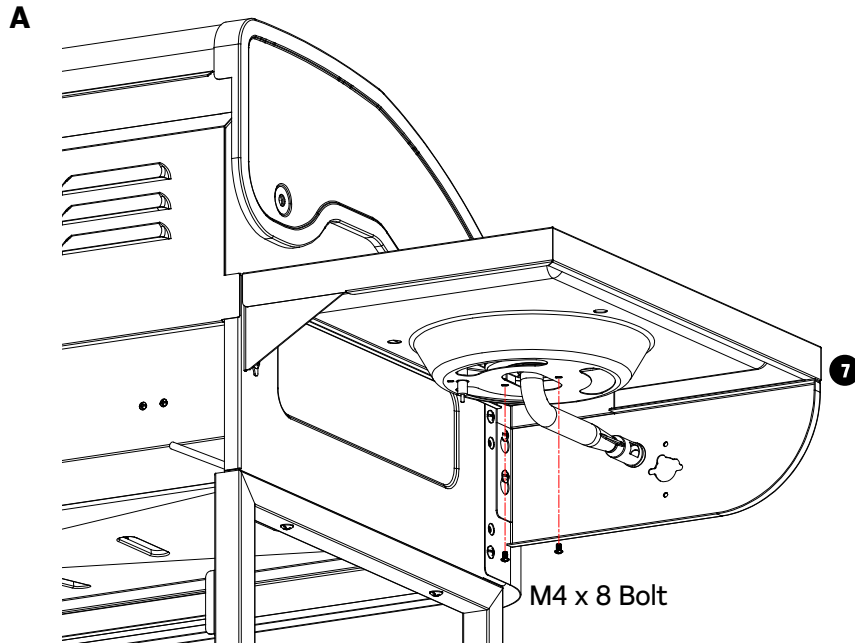

B: Loosen the two pre-assembled screws from the side burner valve bracket on the hose, valve and regulator of the Grill assembly ①.

C: Fix the valve on the side burner control panel using those two screws loosened at procedure B.

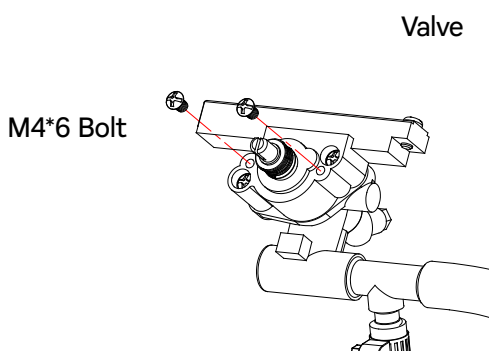

B

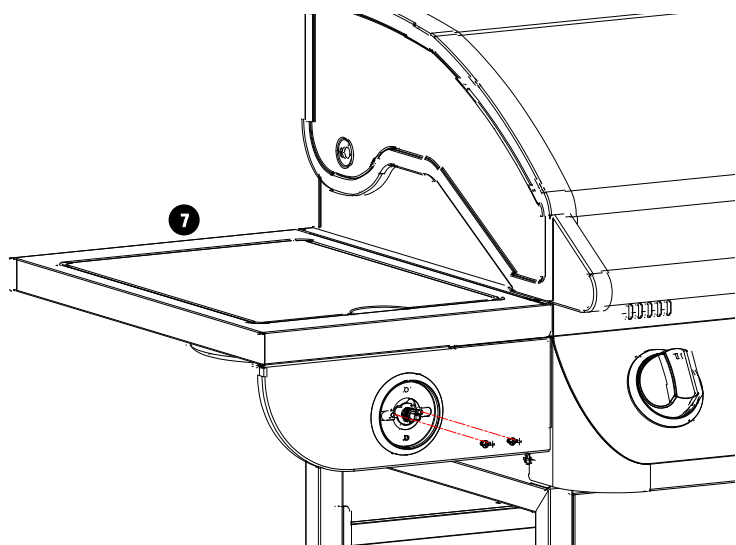

C

- D. Align the side burner venturi against the valve. Make sure the valve tip goes into the burner venturi completely with good alignment. Then tighten those two screws loosened at procedure A on the side burner after the alignment.

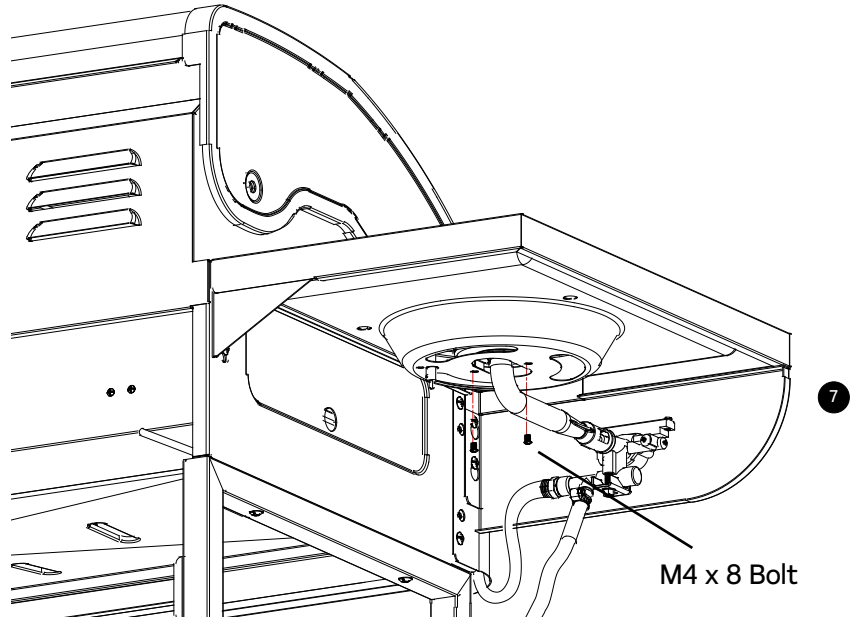

- E. Install the Side burner electrode wire 11 to the side burner electrode and igniter. Connect the black end to the electrode of the side burner assembly 7. Then connect the red end to the igniter of the side burner valve.

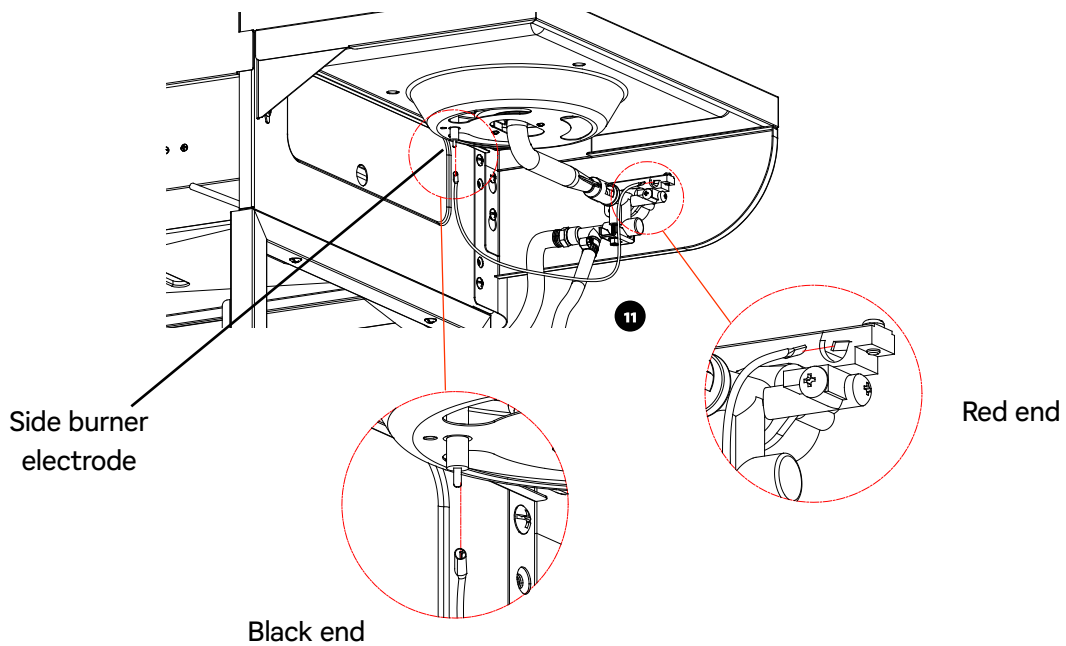

Step 13

Put the Side burner knob **8** on the Side burner assembly **7**.

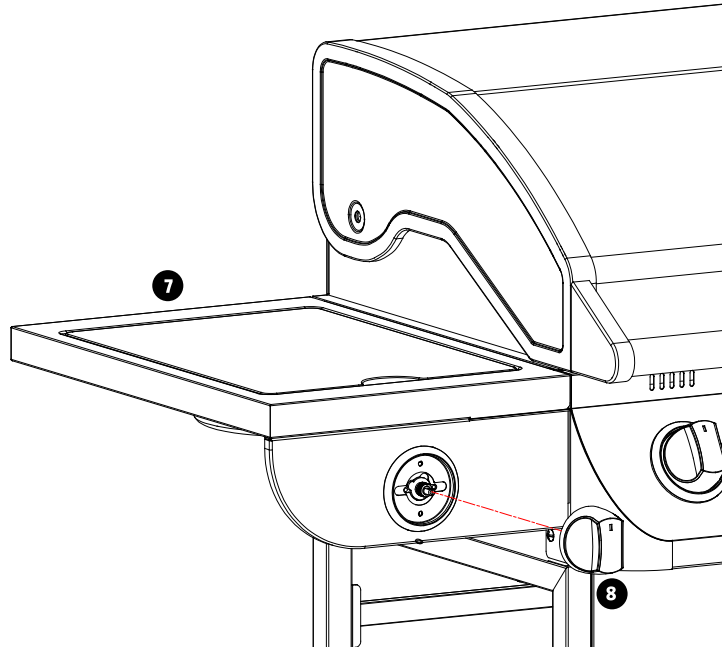

Step 14

Put the Side burner grate **6** on the Side burner assembly **7** and align with the holes.

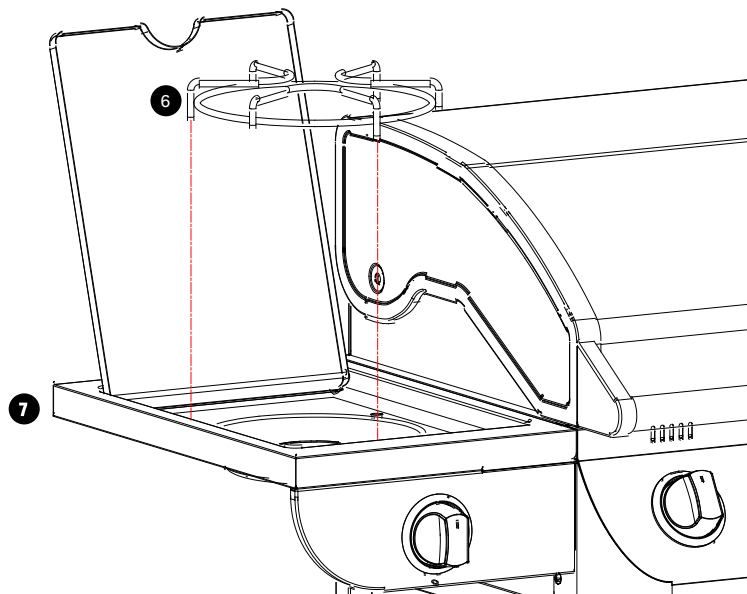

Step 15

Put the Heat tent **4**, Cooking grill **3** and Warming rack **2** on the Grill assembly **1**.

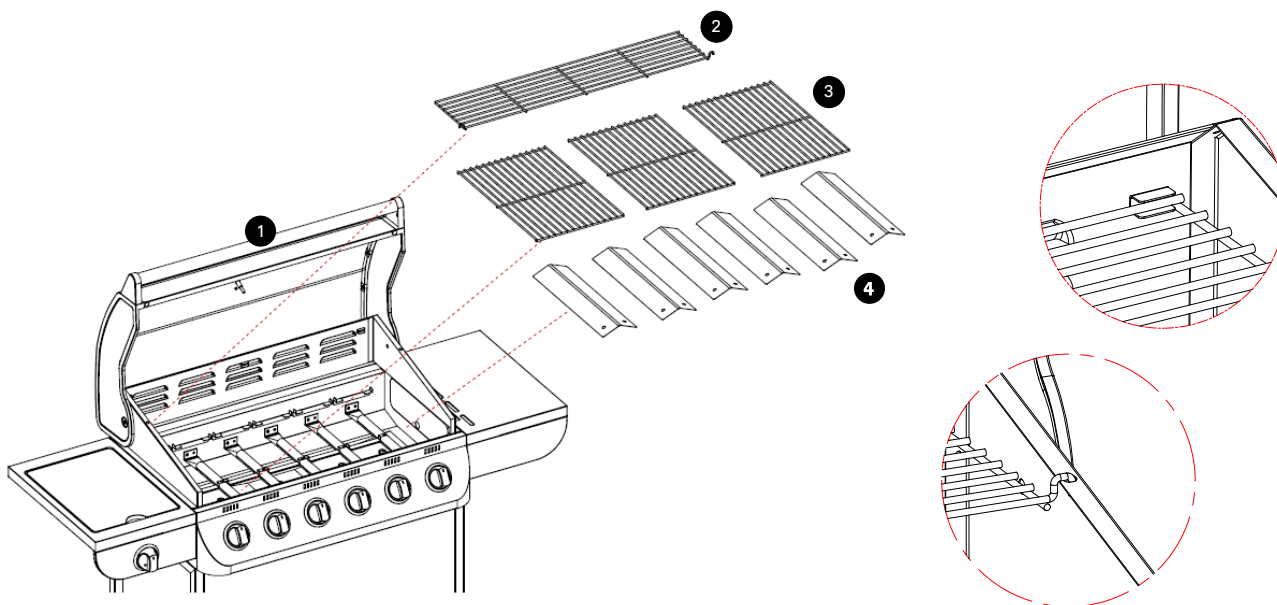

Step 16

Put the grease cup **5** at the bottom of the Grill assembly **1**.

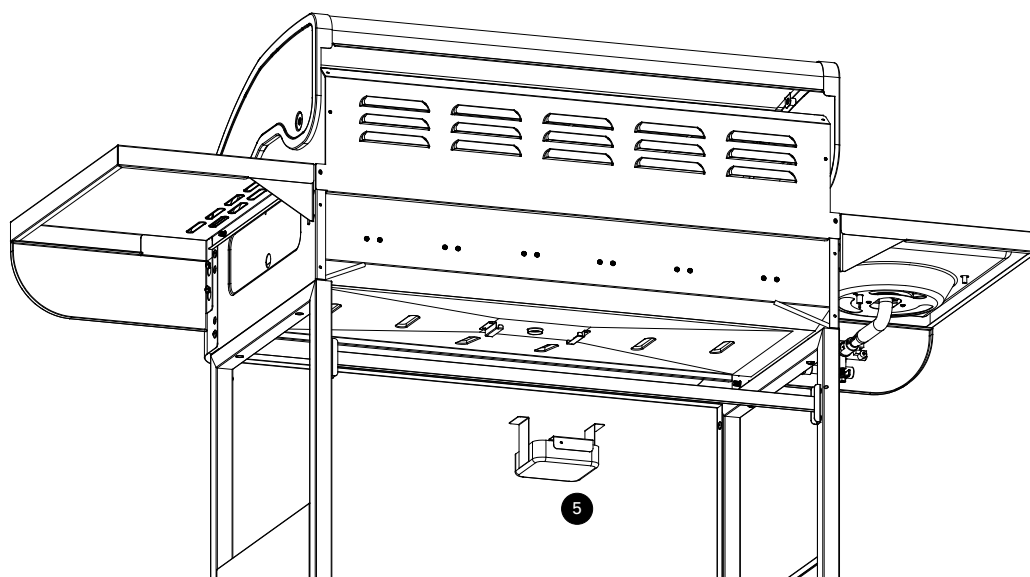

Step 17

Assembly is complete.

ALL JOINTS AND CONNECTIONS MUST NOW BE LEAK TESTED BEFORE USING THE BARBECUE.

Leak test annually, and whenever the gas bottle is removed or replaced.

Please refer to Leak Testing in pg.4.

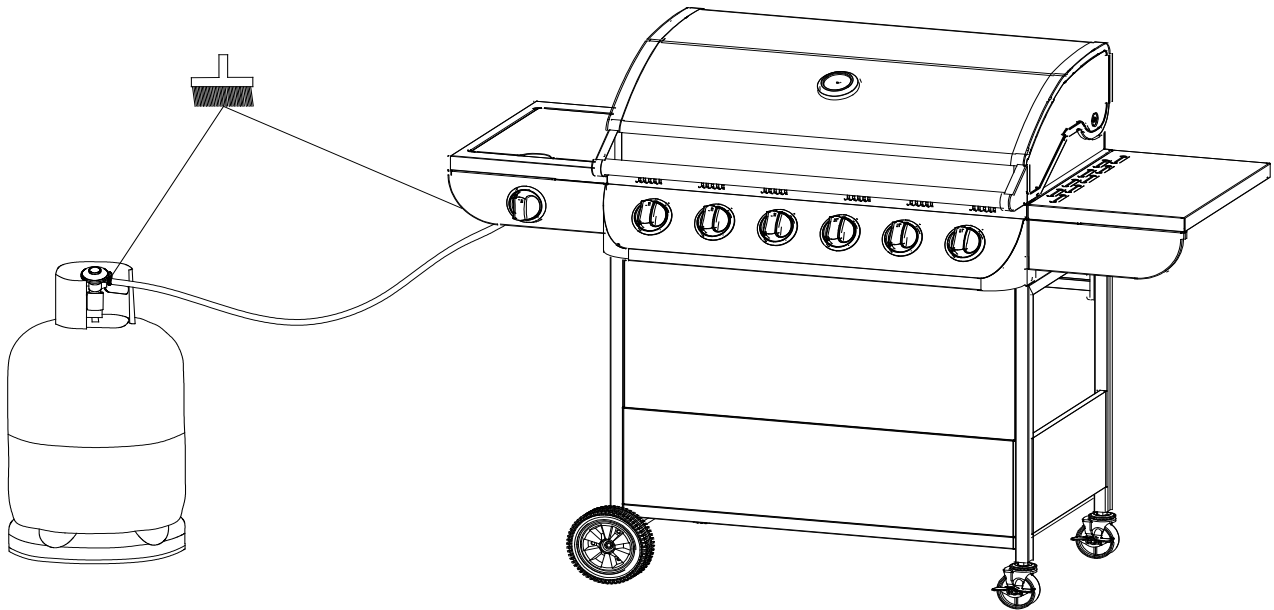

Always place the gas bottle at the side of the appliance. The gas bottle should be sited as far away from the appliance as possible without straining the hose. The hose length should not exceed 1.5m.

TECHNICAL SPECIFICATION

Model Number:	KS16036
Gas Category:	I3+(28-30/37)
Type of Gas: (pressure)	Propane (37 mbar) Butane (28 - 30 mbar)
Pin Number:	0359BU1015/2575DM29973
Injector Size (Main Burner):	0.86mm
Injector Size (Side Burner):	0.94mm
Total Heat Input:	21.08 kW
6 Burner Heat Input:	17.58 kW
Side Burner Heat Input:	3.5 kW
Gas Consumption:	1506 g/h
Country of Destination:	GB and IE

If you need help or have damaged or missing parts,
please contact your local store.

Do not use this barbecue outside UK and Ireland.

HHGL Limited, MK9 1BA
HHGL (ROI) Limited, D02 X576

TROUBLESHOOTING

Problem	Possible Cause	Solution
Burner will not light using the ignition system	LPG cylinder is empty	Replace with full cylinder
	Faulty regulator	Have regulator checked or replaced
	Obstructions in burner	Clean burner
	Obstructions in gas jets or gas hose	Clean jets and gas hose
	Electrode wire is loose or disconnected on electrode or ignition unit	Reconnect wire
	Electrode or wire is damaged	Change electrode and wire
	Faulty push button igniter	Change igniter
Burner will not light with a match	LPG cylinder is empty	Replace with full cylinder
	Faulty regulator	Have regulator checked or replaced
	Obstructions in burner	Clean burner
	Obstructions in gas jets or gas hose	Clean jets and gas hose
Low flame or flashback (fire in burner tube - a hissing or roaring noise may be heard)	LPG cylinder too small	Use larger cylinder
	Obstructions in burner	Clean burner
	Obstructions in gas jets or gas hose	Clean jets and gas hose
	Windy conditions	Use BBQ in a more sheltered position
Gas valve knob difficult to turn	Gas valve jammed	Replace gas valve

