

# SOVEREIGN

EASY GARDENING

## 40CM HAND PUSH PETROL LAWNMOWER

Item No. 644305

Model No. XSS40H



Technical Support & Parts

**01904 727509**

Mon-Fri 9am-5pm Sat-Sun 11am-4pm  
[www.coreservice.co.uk](http://www.coreservice.co.uk)

## ORIGINAL INSTRUCTION MANUAL

Please read these instructions fully before starting assembly.

HHGL Limited, MK9 1BA. HHGL (ROI) Limited, D02 X576

Oct 22

# CONTENTS

General safety warning	3
Intended use	8
Warnings symbols	8
In the box	10
Preparing to assemble the lawnmower	12
Preparing to operate the lawnmower	15
Operating the lawnmower	17
Maintenance	21
Troubleshooting	28
Technical data	29
Disposal	30
Getting help	30
Warranty	31

# GENERAL SAFETY WARNINGS

## SAFETY WARNINGS



**WARNING! Read all safety warnings and instructions.**

Failure to follow the warnings and instructions may result in fire and/or serious injury.



**WARNING! Read all safety warnings and instructions designated by the  symbol.**

**Save all warnings and instructions for future reference.**

- Always ensure anyone intending to operate this lawnmower is fully conversant with the contents of this instruction manual prior to assembling, maintaining or operating the lawnmower.
- Perform assembly operations as described in this manual. Failure to observe this warning may lead to serious injury, death, or damage to the lawnmower.
- Always take care when removing the packaging to prevent damage to you or to the lawnmower.

**IMPORTANT!** Before assembling the lawnmower, check all the parts indicated in the manual are in the box. Inspect all the parts for signs of damage. Do not assemble the lawnmower if you observe any damaged components.

**NOTE!** This lawnmower complies with the Noise Emission Directive 2000/14/EC.

## GENERAL SAFETY

- Keep this operating and maintenance manual in a safe place for reference at a later date.
- Read the instructions carefully. Be familiar with the controls and the proper use of the equipment.
- Never allow children or people unfamiliar with these instructions to use the lawnmower. Local regulations can restrict the age of the operator.
- Never mow while people, especially children or pets, are nearby. Keep in mind that the operator or user is responsible for accidents or hazards occurring to other people or their property.
- This appliance is not intended for use by people (including children) with reduced physical, sensory or mental capabilities, or lack of experience and knowledge, unless they have been given supervision or instruction concerning use of the appliance by a person responsible for their safety.
- Do not touch the rotating blade.

## PERSONAL SAFETY

- **While mowing, always wear substantial footwear and long trousers.** Do not operate the equipment when barefoot or wearing open-toed sandals.
- **Thoroughly inspect the area where the equipment is to be used and remove all objects which can be thrown by the machine.**

- **Petrol is highly flammable; store fuel in containers specifically designed for this purpose.**
  - A. Refuel outdoors only, and do not smoke while refuelling.
  - B. Add fuel before starting the engine. Never remove the cap of the fuel tank or add petrol while the engine is running, or when the engine is hot.
  - C. If petrol is spilled, do not attempt to start the engine but move the machine away from the area of spillage and avoid creating any source of ignition until petrol vapours have dissipated.
  - D. Replace all fuel tank and container caps securely.
- **Replace faulty silencers.**
- **Prior to use, visually inspect to see that the blade, blade bolts and cutter assembly are not worn or damaged.** Replace worn or damaged blades and bolts in sets to preserve balance.

## **OPERATION SAFETY**

- **Do not operate the engine in a confined space where dangerous carbon monoxide fumes can collect.**
- **Mow only in daylight or in good artificial light.**
- **Avoid operating the equipment on wet grass, where feasible.**
- **Always be sure of your footing on slopes.**

- **Walk, never run.**
- **Mow across the face of slopes, never up and down.**
- **Exercise extreme caution when changing direction on slopes.**
- **Do not mow excessively steep slopes.**
- **Use extreme caution when reversing or pulling the lawnmower towards you.**
- **Stop the blade if the lawnmower has to be tilted for transportation when crossing surfaces other than grass, and when transporting the lawnmower to and from the area to be mowed.**
- **Never operate the lawnmower with defective guards, or without safety devices, for example deflectors and/or grass catchers, in place.**
- **Do not change the engine governor settings or over speed the engine.**
- **Start the engine carefully according to instructions and with feet well away from the blade.**
- **Do not tilt the lawnmower when starting the engine.**
- **Do not start the engine without the grass collector located.**
- **Do not put hands or feet near or under rotating parts.** Keep clear of the discharge opening at all times.

- **Never pick up or carry a lawnmower while the engine is running.**
- **Stop the engine and disconnect the spark plug cable, making sure that all moving parts have come to a complete stop.**
  - a) Before clearing blockages or unclogging the chute.
  - b) Before checking, cleaning or working on the lawnmower.
  - c) After striking a foreign object, inspect the lawnmower for damage and make repairs before restarting and operating the lawnmower.
  - d) If the lawnmower starts to vibrate abnormally, check immediately.
- **Stop the engine and disconnect the spark plug wire, make sure that all moving parts have come to a complete stop before refuelling.**

## **MAINTENANCE AND STORAGE**

**Keep all nuts, bolts and screws tight to be sure the equipment is in safe working condition.**

**Never store the equipment with petrol in the tank inside a building where fumes can reach an open flame or spark.**

**Allow the engine to cool before storing in any enclosure.**

**To reduce the fire hazard, keep the engine, silencer, and petrol storage area free of grass, leaves, or excessive grease.**

**Check the grass bag frequently for wear or deterioration.**

**Replace worn or damaged parts for safety.**

**If the fuel tank has to be drained, this should be done outdoors.**

## **INTENDED USE**

This mower is designed for domestic lawn mowing only. Use in any other way is considered contrary to the intended use. Compliance with the operation, service and repair, as specified in this handbook, also constitutes essential elements of the intended use.

## **WARNINGS SYMBOLS**



Read instruction handbook before operating this machine.



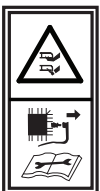

Keep bystanders away.





Beware of sharp blades - remove spark plug lead before maintenance.





 No naked flames.

 Appropriate ear, eye, and head protection (PPE) must be worn.

 Hot surfaces will burn fingers or palms.

 **Warning!** The lawnmower exhaust gas contains toxic substances. Do not run the engine in closed or poorly ventilated areas.

 Blade continues to rotate for a period after the machine is switched off. Do not touch the blade until all the machine components have been stopped completely.

 The product complies with the applicable European directives and an evaluation method of conformity for these directives was done.

 The product complies with the applicable UK directives and an evaluation method of conformity for these directives was done.

 Sound level data (96 dB) in accordance with Directive 2000/14/EC.

# **IN THE BOX**

## **PARTS**

1. Upper handle with soft grip
2. Start/Stop bar
3. Handle fixing knob & square neck bolts x 2
4. Grass collection bag
5. Lower handle
6. Height adjustment handle
7. Wheel
8. Engine
9. Deck
10. Cable clips x 1
11. Rope guide
12. Spark plug spanner
13. Self-tapping screws x 2
14. Screwdriver x 1

You will also need:

- SAE 30 or 4-stroke oil - Unleaded fuel - Funnel

If there are any parts missing, please call the customer helpline on 01904 727509.

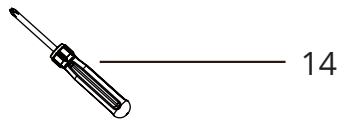
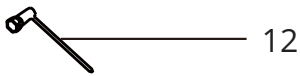
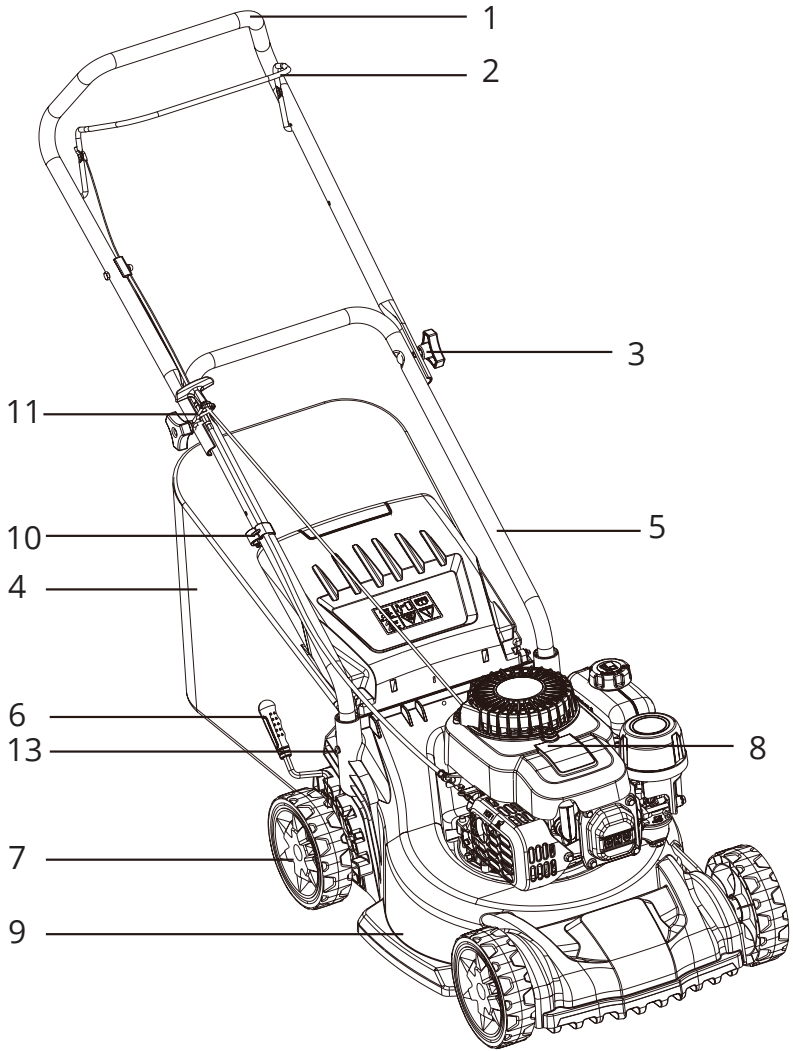

# PREPARING TO ASSEMBLE THE LAWNMOWER



## WARNING!

Always take care when removing the packaging, to prevent damage to you or to the lawnmower.

This item requires a two-person lift to remove it from the packaging. Make sure that you have sufficient space to put the lawnmower down. Keep your feet apart so that you have a stable position; bend at the knees and keep your back straight.

Always recycle the packaging in accordance with local recycling schemes.

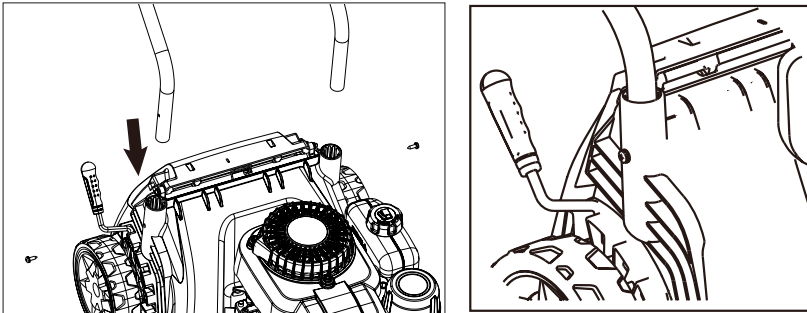

## STEP 1 - ASSEMBLE THE LOWER HANDLE

Remove the packaging from the handle.

Insert the lower handle into the deck, as shown, for each side. Ensure the hole in the lower handle correspond to the hole in the deck, and fix the lower handle with a self-tapping screw.

## STEP 2 - ASSEMBLE THE UPPER HANDLE

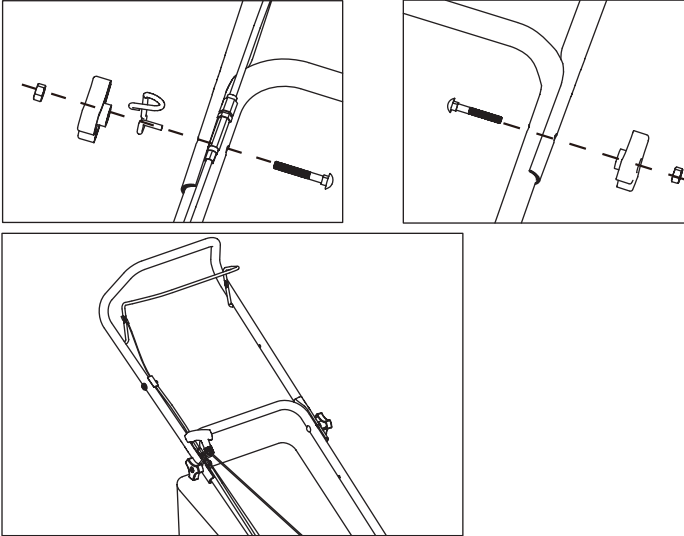

Lift the upper handle, and lock in place using the handle tension knob and nuts. Make sure that you attach the rope guide between the handle and tension knob.

Ensure the lower and upper handles are firmly connected.

When you stand behind the mower, ensure the rope guide is on the right handle.

## STEP 3 - ASSEMBLE THE GRASS BAG

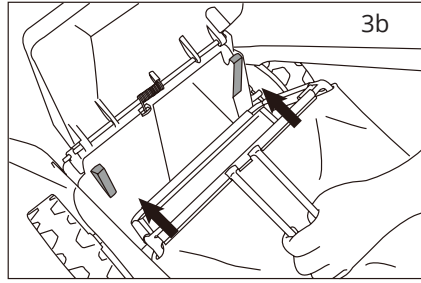
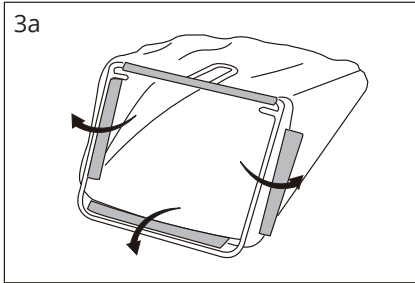

3a. Firstly, attach the grass bag to the frame by fixing all plastic hooks.

3b. Raise the safety flap, and hook the collection bag onto the mower. Release the safety flap.

## STEP 4 - ATTACH THE CABLE CLIP

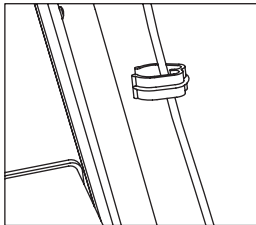

Ensure that the cable clips supplied are used to fix the cable to the lower handle.

**STOP!**

**Do not start the engine before putting 400ml of SAE 30 oil into the engine.**

**Failure to do so will result in irreparable damage to the engine and invalidate your warranty.**

# PREPARING TO OPERATE THE LAWNMOWER

## STEP 1 - FILLING WITH ENGINE OIL



### IMPORTANT

The following procedures and adjustments must be performed before the engine is started. Do not attempt to make any of these adjustments while the engine is running.

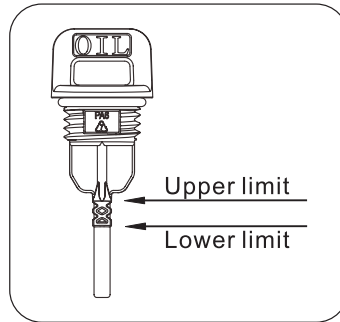
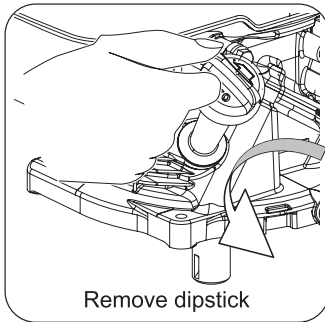

Always use high-quality detergent oil classified SAE 30 oil (or equivalent, e.g. 5W 30, often termed as 4-stroke lawn mower oil). Only use additives recommended by the engine manufacturer. To prolong the life of your engine, it is important that the oil is changed after the first 5 hours of use. Using non-detergent oil can shorten the engines service life, and using 2-stroke oil will damage the engine.

To prevent engine damage, the engine is shipped without oil or petrol. The engine must be filled with the correct grade of oil and petrol before starting the engine.

Running the engine with a low oil level will cause irreparable engine damage.

Check the engine oil level with the engine stopped and the mower on a level surface.

Remove the oil filler dipstick and wipe oil from it with a clean cloth.

Insert the dipstick into the oil filler neck but do not screw it in.

Then remove the dipstick and check the oil level. The oil level must be between the min. and max. marks on the dipstick. If near the lower level, fill to the upper level with the recommended oil (SAE 30 or equivalent). Do not overfill. Wipe away any spilt oil.

## STEP 2 - FILLING WITH ENGINE FUEL



**WARNING!** Refuel in a well-ventilated area with the engine stopped. Do not smoke or allow flames or sparks in the area where the engine is refuelled or where petrol is stored. Avoid repeated or prolonged contact with skin or inhalation of vapour.



**CAUTION!** Petrol is highly flammable and extreme precaution must be taken when handling or working with it. Keep out of reach of children.

1. Clean the area around the petrol filler cap before removing the cap. Remove the warning tag and check the fuel level.
2. Refill the tank if the fuel level is low. Always use clean, fresh unleaded petrol. Purchase fuel in quantities that can be used within 30 days. Never mix oil with petrol.
3. Refuel carefully to avoid overfilling or spilling fuel to allow for expansion. There should be no fuel in the filler neck.
4. Clean up any overflow or splashes of petrol before starting the engine.
5. Tighten the filler cap after filling, finger tight only.

**NOTE!** The Sovereign 40cm Hand Push Lawnmower has a maximum fuel capacity of 900ml.



# OPERATING THE LAWNMOWER

## STEP 1 - SETTING THE CUTTING HEIGHT



**WARNING!** The blade can cause serious injury. Before adjusting the mower height, stop the engine and wait for the mower blade to stop completely.

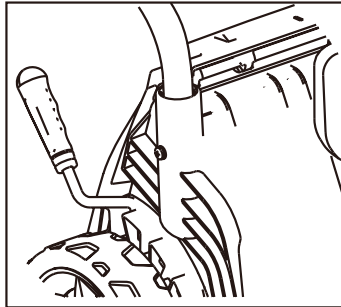

1. Pull the lever towards the wheel, then move it forward or backward to adjust the cutting height.
2. Move it to any one of the 5 positions for the desired cutting height.
3. Return lever into the securing plate.



**NOTE!** Never use the lowest cutting height for the first cut of the season or in drought conditions. Only about one third of the grass height should be cut.

## STEP 2 - STARTING THE ENGINE

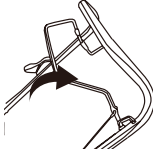

**WARNING!** Do not operate the machine in enclosed or poorly ventilated areas as the exhaust gas contains toxic substances. Keep hands, feet, hair and clothing away from all the moving parts of the machine. The exhaust and other parts of the machine will become hot during use. Make sure that the blade is securely fastened before starting the engine.

### 1 Starting procedure quick guide for cold start

PRIMER BULB 3~5 TIMES FOR COLD START	STOP/START-LEVER CLOSED	PULL STARTING HANDLE
1 	2 	3 

To start the engine, make sure that the spark plug cap is located on the plug and the machine is filled with sufficient oil and petrol.

#### 1-1 Press the primer bulb (A) 3-5 times

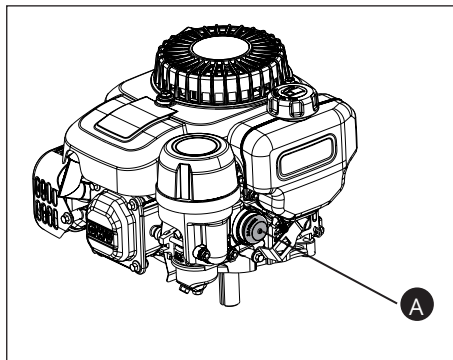

When starting a cold engine, press down the primer fully 3-5 times.

**Pressing the primer button too many times could cause the engine to flood.**

**NOTE!** When starting a warm engine, the primer does not need to be used. If the engine stops due to a lack of petrol, refill and press down the primer 3-5 times.

## **1-2 Start/Stop bar activation**

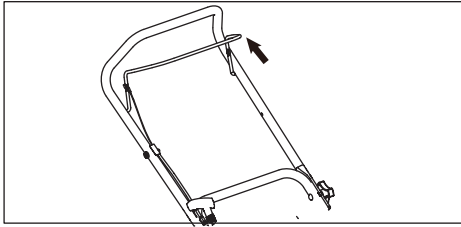

Pull the Start/Stop bar towards you.

## **1-3 Pull cord handle**

With the right hand, slowly but firmly pull the starter handle and rope from the pull cord guide until you feel resistance, then pull briskly. If the engine fails to start after three pulls, repeat the start process. When the engine starts, return the starter rope to the pull cord guide gently.

**Do not use the primer bulb for hot start.**

## **STEP 3 - TO STOP, RELEASE STOP/START BAR**

### **Failure to start**

If the engine won't start after you have operated the starter several times, the engine may be flooded with excess fuel.

Use the following procedure to clear and start a flooded engine:

- A. Release the stop/start bar.
- B. Remove the spark plug, dry it, and then reinstall it.

Install the spark plug carefully by hand, to avoid cross-threading. After the plug is seated, tighten 1/8 to 1/4 turns with socket spanner of spark plug to compress the washer.

C. Pull the stop/start bar towards the upper handle.

D. Operate the starter as described above.

## STEP 4 – MOWING



**WARNING!** Always observe the strictest safety procedures when using the lawnmower.

### Mowing with grass bag

Start the engine and allow it to run. See 'Step-2 Starting the engine'.

Keep a firm grip on the upper handle with the stop/start bar and push the lawnmower forward and walk along with it, never run with the mower. Be very careful when mowing uneven or rough ground.



**WARNING!** Do not use the mower on a steep slope of more than 15°. Be careful when changing the direction of the mower on a slope.

### NOTE!

The best result will be achieved if the grass is dry. Wet grass will tend to clog the blade and the grass collection system. Grass grows at different rates at different times of the year.

Never use the lowest cutting height for the first cut of the season or in drought conditions. Only about one third of the grass height should be cut.

If the lawnmower will not collect the cuttings efficiently, the grass discharge chute may be blocked, the grass bag may be full, or the underside of the mower deck may be clogged.

## STEP 5 - EMPTYING THE GRASS BAG

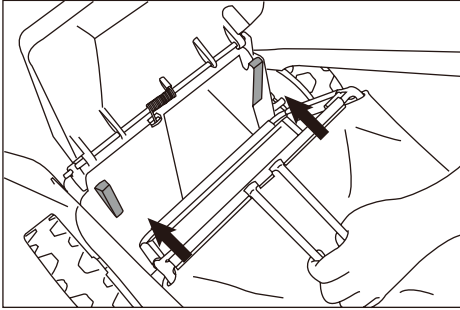

Raise the discharge flap with one hand and remove the grass bag using its handle with your other hand. To maintain safety, the discharge flap will close back to cover the mulching plug when you release the flap.

Empty the grass debris in the grass collection bag and refit the bag. If any grass residues are caught in the discharge chute, clean it using a brush.

## MAINTENANCE

### STORING THE LAWNMOWER FOR SHORT PERIODS

After mowing, please follow the actions below prior to placing the lawnmower in storage:

- Allow the engine to fully cool.
- Ensure the grass bag is empty.
- Clean all debris from under the mower deck.
- Store the lawnmower on a flat and level surface, with all 4 wheels on the ground.
- Store in a safe place which is not accessible by children or people who are not familiar with operation.

## STORING THE LAWNMOWER FOR EXTENDED PERIODS



**CAUTION!** Do not empty the petrol tank in enclosed areas, near fire or when smoking. Petrol fumes can cause explosions and fire.

If the lawnmower is to be placed into storage at the end of the season, or if the mower is not to be used for a longer period than 6 weeks, storage maintenance must be performed on the lawnmower.

The temperature fluctuations cause condensation, which contaminates fuel and causes starting problems. Simply emptying the machine of fuel will prevent this.

1. Empty the petrol tank with a petrol suction pump, if available, or use the tipping method.
2. Start the engine and let it run until any remaining petrol has been used up.
3. Change the oil at the end of every season. To do so, remove the used engine oil from a warm engine and refill with fresh oil.
4. Remove the spark plug from the cylinder head. Fill the cylinder with approx. 20ml of oil from an oil can. Slowly pull back the starter handle, which will bathe the cylinder wall with oil. Screw the spark plug back in.
5. Clean the cooling fins of the cylinder and the housing.
6. Be sure to clean the entire machine to protect the paint.
7. Store the machine in a well-ventilated place.

**NOTE!** Alternatively, adding Briggs & Stratton FUEL FIT to the fuel will prevent contaminated fuel. Not all additives on the market do this. FUEL FIT can be ordered via [www.coreservice.co.uk](http://www.coreservice.co.uk)

## PREPARATION TO RE-USE

Check the oil level before starting the engine and ensure there is sufficient oil, see page 7.

Check the spark plug is inserted correctly, see page 25.

Fill engine with fresh unleaded fuel, see page 16.

Follow starting procedure, see page 18.

## MAINTENANCE SCHEDULE



### WARNING!

- Before you tip the lawn mower onto its side, completely empty the fuel tank using a petrol suction pump.
- Never turn the mower upside down.
- Before commencing any maintenance, always disconnect the spark plug.

Performing routine maintenance correctly on your lawnmower will ensure you get years of trouble-free use.

Please keep this manual safe for future reference.

It is recommended that the following maintenance schedule is adhered to. This will ensure the lawnmower operates correctly and is safe to use.

	<b>after every use</b>	<b>12 hours of use</b>	<b>24 hours of use</b>	<b>36 hours of use</b>
Cleaning	clean	clean	clean	clean
Air filter		clean	clean	replace
Spark plug		check	clean	replace
Engine oil	check	check	replace	check
Cutting blade	check	check	check	replace

**The engine oil should be changed after the first 5 hours.**

## CLEANING

To ensure long life and good performance of the machine, it's important to keep the machine clean and well lubricated. Make sure the chute is clean and under the deck is cleared from wet debris. (See also short term storage).

- Do not allow grass cuttings and other debris to become dry and hard on any of the mower surfaces. This will directly affect the cutting and grass collection performance. Make sure that the underside of the lawnmower deck is clean and clear.
- Never clean the lawn mower with a water jet or high-pressure cleaner. The engine must remain dry. Do not use aggressive cleaning agents or solvents, such as cold degreasers or petroleum ether.

## CLEANING OR REPLACING AIR FILTER



**WARNING!** Never run the engine without the air filter element installed.

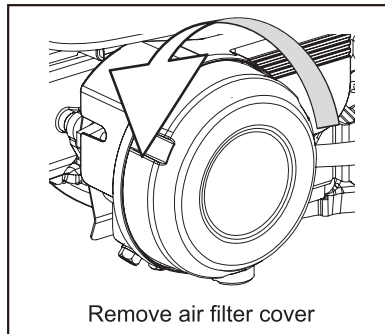

1. Loosen the fastener that holds the cover.
2. Open the cover and remove the filter.
3. To loosen debris, gently tap the filter on a hard surface. If the filter is excessively dirty, replace with a new filter.
4. Install the filter.
5. Install the cover tabs into the slots.
6. Close the cover and secure with the fastener.



## CLEANING OR REPLACING THE SPARK PLUG

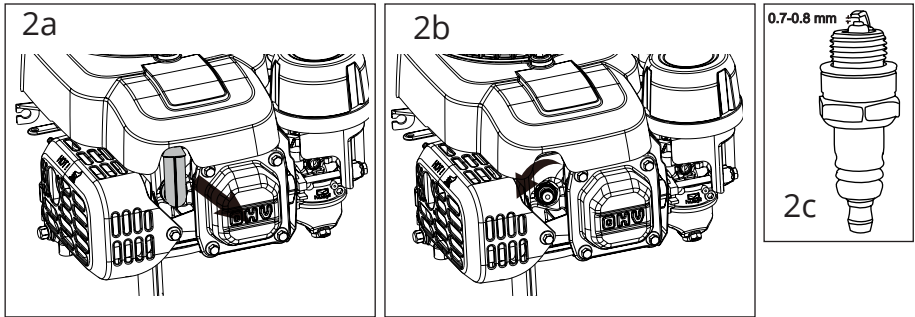

2a Once the engine has cooled, pull off the spark plug boot with a twist. Remove the spark plug using the socket spanner supplied.

2b Clean the plug with a wire brush.

2c Using a feeler gauge, set the gap to 0.7mm.

2d Install the spark plug carefully by hand to avoid cross-threading.

2e After the spark plug is seated, tighten with the spanner to compress the washer.

## CHANGING THE OIL

Tilt the lawnmower towards the oil filler, have a container ready to catch the oil, and remove the dipstick. Once the oil has been emptied, wipe clean any spillages.

Refill with 400ml SAE 30 oil or equivalent, i.e. SAE 5W/30, SAE 10W/30). When the dipstick is rested on the filler pipe, the oil level must be between the min. and max. marks on the dipstick.

See 'Filling with Engine Oil'. Do not overfill.

Start the engine and allow it to run briefly.

Stop the engine, wait one minute and check the oil level. Top up if necessary.

## REPLACING THE CUTTING BLADE



### **WARNING! USE GLOVES.**

- Before you remove the grass collection bag, stop the engine and wait until the blade stops completely.
- You will need garden gloves (not provided) and a spanner wrench to remove the blade.
- Always handle the blade with care - sharp edges could cause injury.
- Don't hold the blade by hand directly.

### **Replace your metal blade after 50 hours mowing or after 2 years, which ever is sooner regardless of condition.**

Regularly check your blade. If the cut of your grass is poor, the blade might be blunt. Damaged blades not only result in a bad cut, they cause excessive vibration and uneconomical running of the engine. If the blade has worn excessively and become pitted and blunt, it should be replaced or sharpened.

**NOTE!** The blade carrier is designed to break under heavy blade impact to protect the machine. If this happens, also replace the blade carrier. This can be purchased from [www.coreservice.co.uk](http://www.coreservice.co.uk)

Use a torque wrench to tighten the blade bolt by 40 N·m

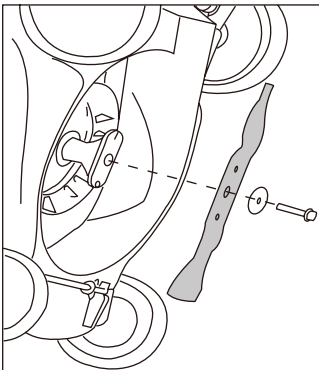

1. Tip the machine slightly towards the oil filler pipe and reach under the deck.
2. Hold the blade and unscrew the blade bolt counterclockwise using a spanner wrench. Remove the washer and the blade.
3. Inspect the blade adaptor for any signs of damage.
4. Fit a new blade, locate the blade on the two studs on the blade flange and then replace the washer and bolts.
5. Check the washer is still slightly domed to keep the pressure on the bolt to stop it unwinding, keeping the blade firmly secure. Then replace the washer (right way around!) and bolts.
6. Make sure the blade is correctly located, and then firmly tighten the bolt. Do not over tighten. The up turn of the blade must project into the motor compartment.

**NOTE!** If you are unsure about performing this operation, call our helpline or go to an authorised dealer to change the blade for you.

List of consumable parts:

TORCH/ F5RTC	Spark plug	916204	Blade bolt
916901	Collection grass bag	1003108000	Fixing knob
1181206	Blade		

Parts can be ordered via [www.coreservice.co.uk](http://www.coreservice.co.uk)

# TROUBLESHOOTING



## WARNING!

- Always switch off the engine and pull the ignition cable before starting any inspection or adjustment work.

- If after making an adjustment or repair to the engine you let it run for a few minutes, remember that the exhaust and other parts will get hot.

The following table provides solutions to common problems encountered with the lawnmower:

<b>Fault</b>	<b>Possible cause</b>	<b>Solution</b>
Loud while running, machine vibrates heavily	<ul style="list-style-type: none"> <li>- Screws are loose</li> <li>- Blade fasteners are loose</li> <li>- Blade is unbalanced</li> </ul>	<ul style="list-style-type: none"> <li>- Check screws</li> <li>- Check blade fasteners</li> <li>- Replace blade</li> </ul>
Engine does not start	<ul style="list-style-type: none"> <li>- Start/stop bar not pressed</li> <li>- Primer bulb is empty</li> <li>- Spark plug is defective</li> <li>- Fuel tank is empty</li> <li>- Engine may be flooded</li> </ul>	<ul style="list-style-type: none"> <li>- Press start/stop bar</li> <li>- Press primer bulb 3~5 times</li> <li>- Replace spark plug</li> <li>- Refill with fuel</li> <li>- Remove plug and dry, see page 24</li> </ul>
Engine runs unsteadily	<ul style="list-style-type: none"> <li>- Air filter is soiled</li> <li>- Spark plug is soiled</li> </ul>	<ul style="list-style-type: none"> <li>- Clean the air filter</li> <li>- Clean the spark plug</li> </ul>
Uneven mowing results	<ul style="list-style-type: none"> <li>- Blade is blunt</li> <li>- Cutting height is too low</li> </ul>	<ul style="list-style-type: none"> <li>- Sharpen the blade</li> <li>- Set correct height</li> </ul>
Unsatisfactory grass collection	<ul style="list-style-type: none"> <li>- Cutting height is too low</li> <li>- Blade is worn</li> <li>- grass bag is clogged</li> </ul>	<ul style="list-style-type: none"> <li>- Set correct height</li> <li>- Replace the blade</li> <li>- Empty the grass bag</li> </ul>

# TECHNICAL DATA

Property	Value
Model No.	XSS40H
Engine type	Single cylinder 4-stroke
Engine displacement	132cm <sup>3</sup>
Rated engine power	2.6kW / 3600 rpm
Max. operation engine speed	2900/min
Cutting height	25~75mm/ 5 positions
Cutting width	40cm
Grass bag capacity	45L
Ignition	T.C.I
Fuel tank capacity	0.9L
Oil tank capacity	0.4L
Sound pressure level	80.3 dB(A), K <sub>PA</sub> =3.0 dB(A)
Sound power level	90.2 dB(A), K <sub>WA</sub> =3.0 dB(A)
Guaranteed sound power level	96 dB(A)
Vibration	Left :4.48 m/s <sup>2</sup> , Right:4.97m/s <sup>2</sup>
Spark type	F6RTC
Net weight	17.1kg

## DISPOSAL

The lawnmower and its accessories are made of various recyclable materials. Dispose of the lawnmower in accordance with your local recycling regulations.

## GETTING HELP

Our dedicated UK-based customer helpline is open 7 days a week to assist you with assembly, parts queries and technical support. We are open during office hours but you can always send an email via **support@coreservice.co.uk**. Our experts are here to get you back enjoying your garden in no time.

For useful assembly, starting and maintenance videos, and ordering spares, please visit **www.coreservice.co.uk**.

Calling our service does not affect your statutory rights.

## **WARRANTY**

This product is covered by a 1 year warranty.

The warranty covers any manufacturing defect in materials, workmanship and finish.

Any claim under this warranty must be made by going to your nearest Homebase store, taking your proof of purchase with you, and claims must be made within 1 year of the date of purchase.

We will offer you a free repair of the item where this is possible, or a replacement or a refund. Your statutory rights remain unaffected, in particular any rights you may have under the Consumer Rights Act 2015.

This warranty is given by HHGL Limited, MK9 1BA, HHGL (ROI) Limited, D02 X576.

Please note: This warranty does not apply to products misused or neglected and only covers domestic use. It does not apply to commercial use of the product. In addition, the warranty will be void for the following reasons: Any damage resulting from product misuse or product neglect.