

EDALE 4 LIGHT  
DINER BAR  
PENDANT LIGHT

**HOMEBASE**  
**EDIT**

Diagrams shown for illustration purposes only - product may differ slightly from the ones shown overleaf.

This product should be disposed of responsibly at the end of its life. Please recycle where facilities exist. Check with your local authority or retailer for recycling advice.  
(Waste Electrical and Electronic Equipment Directive)



**INSTRUCTION MANUAL**

**IMPORTANT:** Please read these instructions before using the product and retain for future use.

HHGL Limited, MK9 1BA  
HHGL (ROI) Limited, D02 X576

## SAFETY AND CARE ADVICE

For your safety, this product must be installed in accordance with local building regulations. If in any doubt, or where required by law, consult a competent person who is registered with an electrical self-certification scheme. Further information is available online or from your local authority.

This product has been designed for non-professional, domestic use only.

Dispose of all packaging components correctly and responsibly and in accordance with all local laws and regulations. Never leave packaging components within reach of children, as they can be a source of danger.

Before inserting or replacing a bulb, ensure the power is switched off and the bulb has cooled down.

Do not modify any product before or after installation. This may render the product unsafe.

This is a Class 2 product and does not require an earth connection.

This fitting must be permanently wired to the electric system.

Always shut off the power to the circuit before starting installation.

## WARNINGS

This product is not intended for use by persons (including children) with reduced physical, sensory and mental capabilities, or lack of experience and knowledge, unless they have been given supervision or instruction concerning the use of the product by persons responsible for their safety.

Children should be supervised to ensure that they do not play with the product.

Do not place this fitting in a damp atmosphere.

## CARE AND MAINTENANCE

Always disconnect the power supply when servicing or cleaning.

Use a clean, soft, dry or slightly damp cloth for cleaning this product.

Do not use abrasive cloths or polishes, as this may cause damage to the product.

## CHANGING BULBS

This product requires 4 x 10W max. E27 LED GLS bulbs (bulbs not included).

This fitting is suitable for dimming when connected to an external dimming switch and using suitable LED dimmable bulbs.

Ensure that the power supply has been disconnected and the bulb has cooled down before replacing.

## PARTS LIST

Pendant light x 1  
Mounting screws x 2  
Wall plugs x 2  
Glass shades x 4

## FIXING INSTRUCTIONS

This light fitting is double insulated and must not be earthed. Do not attach any part of it to an Earth wire or terminal.

Make sure that there is a joist or other solid mounting at the point of fixing. This is necessary to take the weight of the fitting.

Double insulated items (Class 2): These are marked with this symbol:



The height of this fitting may be adjusted by loosening the grub screw located underneath the ceiling cup.

Coil any excess cable inside the ceiling cup.

Retighten the grub screw to set the fitting at the desired height.

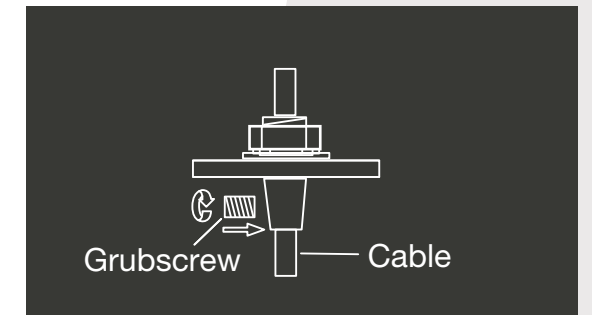

## ASSEMBLY

**Step 1** Taking care not to damage any house wiring, detach the mounting strap from the fitting and affix to the ceiling using the screws supplied.

These screws should penetrate the joist by at least 2cm.

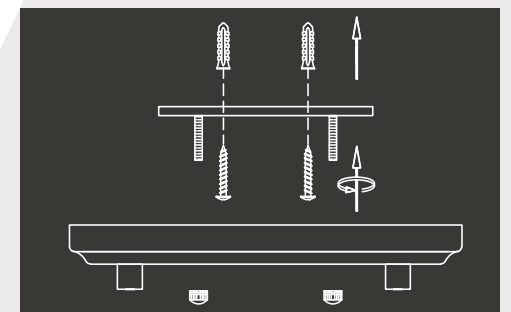

**Step 2** Using the connector block supplied, connect the wires as shown on the diagram shown right.

Check that you have correctly identified the house wires, that all connections are tight and that no loose strands have been left out of the connection blocks.

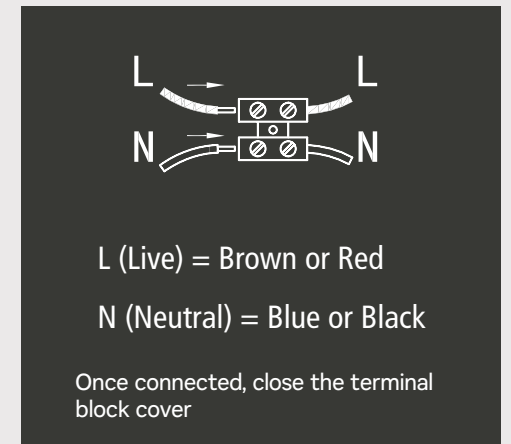

**Step 3** Offer the ceiling cup up to the mounting strap and secure in place using the screws/washers.

**Step 4** Carefully screw the shade onto the lamp holder. Take care not to over tighten.

**Step 5** Insert the bulbs into the lampholders.