

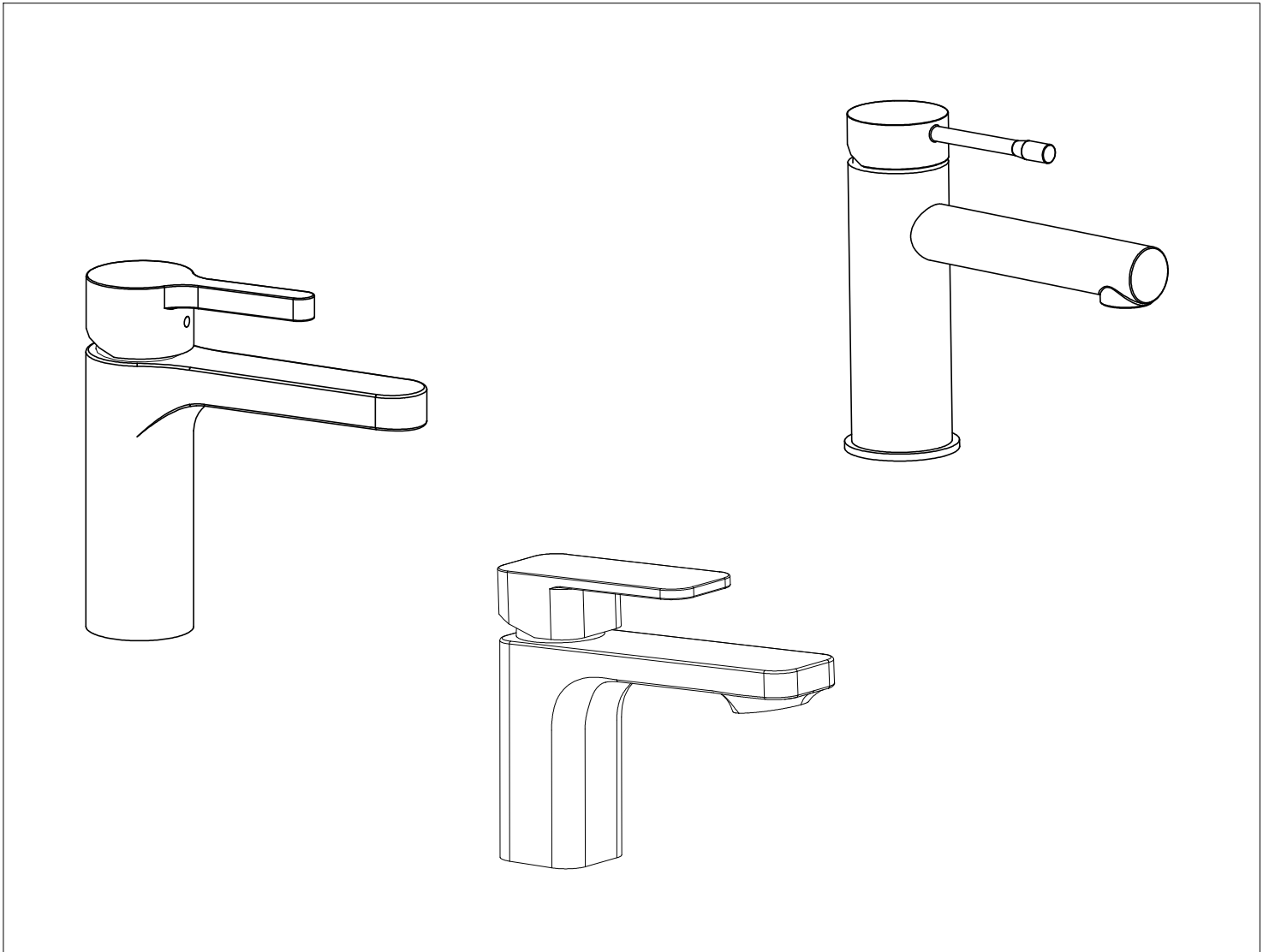

INSTALLATION MANUAL

Single Lever Basin Mixer



VURTU is registered trade mark of Kinen UK Limited.
the company reserves the right to alter product
specifications without notice

Tools needed

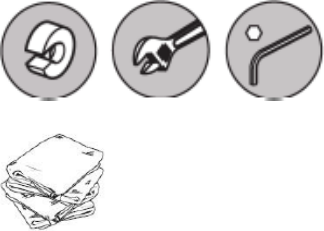

Dynamic Water Pressures

Min: 0.2 bar Max: 5.0 bar

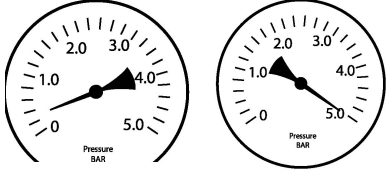

Maximum Static Pressure: 10.0 bar

<h2>Troubleshooting</h2>		
Symptom	Cause	Remedy
No flow or low flow rate	Partially closed isolation valve.	Open isolation valve.
	Instantaneous water heater cycles on and off as flow rate or pressure is too low.	Increase water flow rate or pressure through system.
	Head of water is below the minimum distance required.	Refer to specification for minimum distance required.
	Hot or cold water being drawn off elsewhere causing pressure changes or instantaneous boiler temperature changes.	Do not use other water outlets when using the taps.
	Airlock or partial blockage in the supply pipework.	Flush through pipework to ensure removal of debris and any airlocks.
Water dripping from taps	This is normal for a short time after using the taps.	This is caused by residual water tension, the build up of water in the tap body.
	If water continues to drip, possibly due to the ceramic disc valves	Remove valves and clean, refer to 'Maintenance' section before starting any maintenance.
Taps do not turn on	Closed isolation valve.	Open isolation valve.
	Mains water supply turned off.	Turn on mains water supply.

1. NOTES FOR INSTALLATION

 **Warning:** Please read all the instructions completely before proceeding.

- 1) The installation must comply with the "Water Supply Regulations 1999 (Water Fittings) or any particular regulations and practices specified by the local water company or water undertakers.
- 2) Minimum and Maximum working pressure : 0.2 - 5 bar
- 3) Please do not connect hot and cold water supply lines in reverse. This could result in scalding.
- 4) The hot water temperature must not exceed 65°C. Exceeding 65° may cause scalding, the service life of your tap might be shortened, or the product might be damaged.

2. SHUT OFF WATER SUPPLY

Locate water supply inlets and shut off the water supply valves. These are usually found under the sink or near the water meter.

3. INSTALLATION

Insert the two inlet hoses (6C) into the tap (6A). From above the basin, place the inlet hoses(6C) and shank-thread (6B) through Hole onto the basin

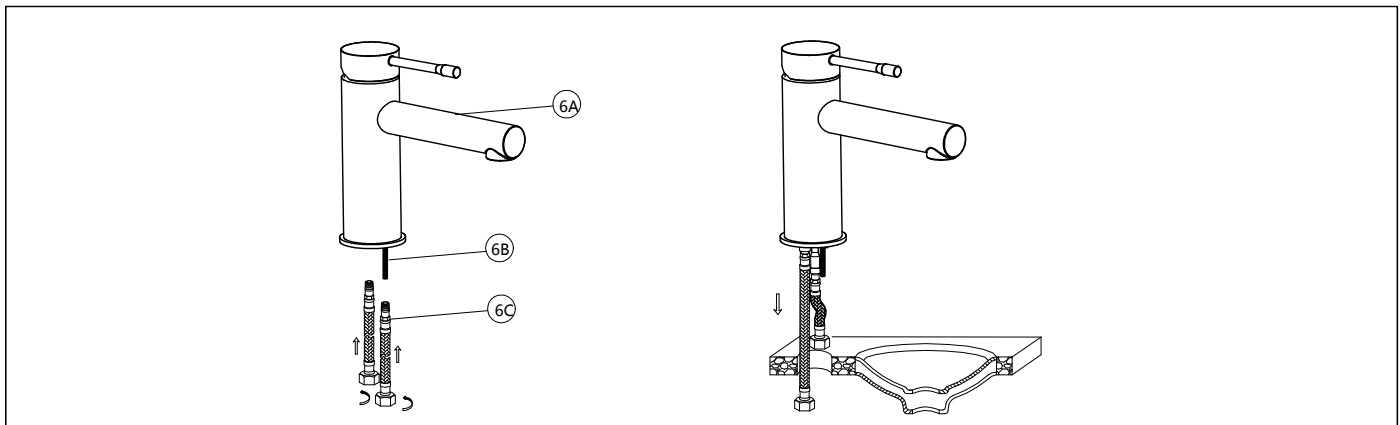

4. SECURING TAP

From underneath basin, secure tap body (7A) by placing rubber washer (7F,) metal washer (7B) and threading long nut (7C) onto mounting post (7D) make sure that the ribbed edge metal gasket (7B) is facing up. Use the install tool to tighten long nut (7C). secure long nut (7C) not to exceed a 1/4 turn.

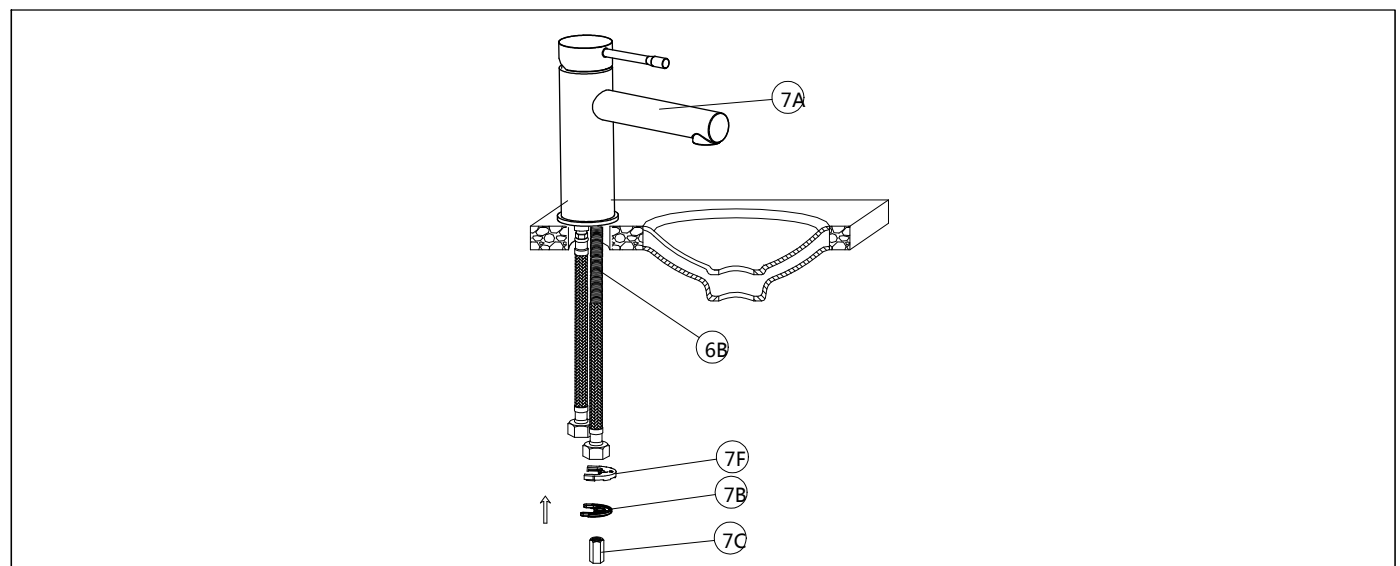

5. WATER SUPPLY CONNECTION

Insert the washers into the connector of the hot and cold flexible hoses. Connect the hot and cold hoses to the isolating valves (valves recommended but not included)

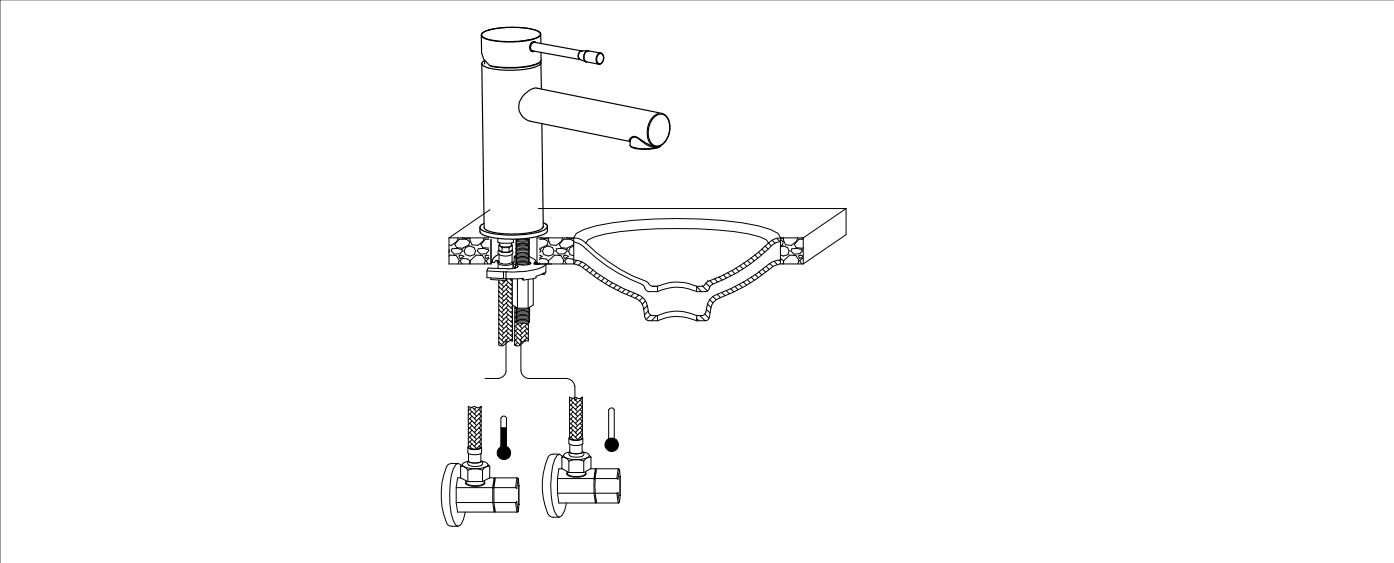

6. TESTING

Turn on hot and cold water supplies and check for leaks above and below installation.

7. VALVE FUNCTIONS

By lifting the lever handle upwards, the valve will be activated. Water flow will increase by continuing to lift up the lever handle. By rotating the lever handle anti-clockwise, the water temperature will decrease. By rotating the lever handle clockwise, the water temperature will increase.

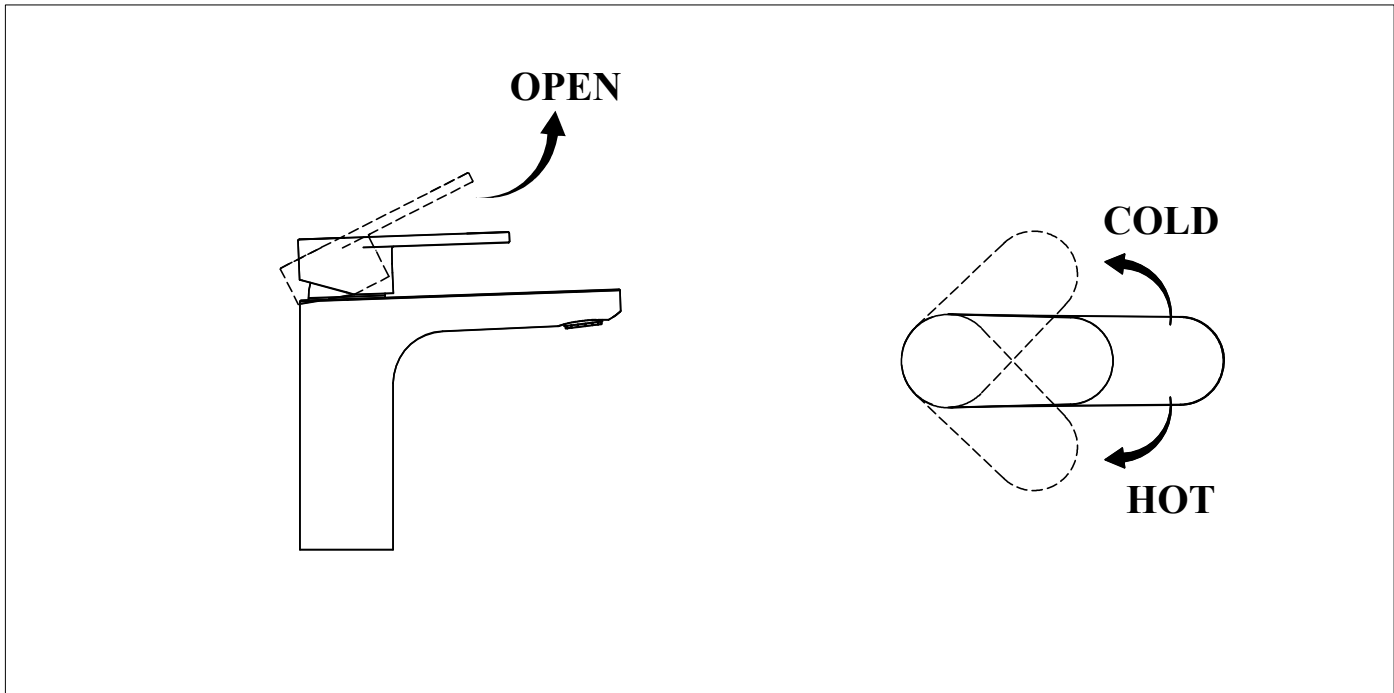

8. ⚠️ CLEANING / MAINTENANCE OF AERATOR

To avoid debris from installation, it is recommended to clean the aerator as it could affect the water flow performance. It is also recommended to clean the aerator on a regular basis.

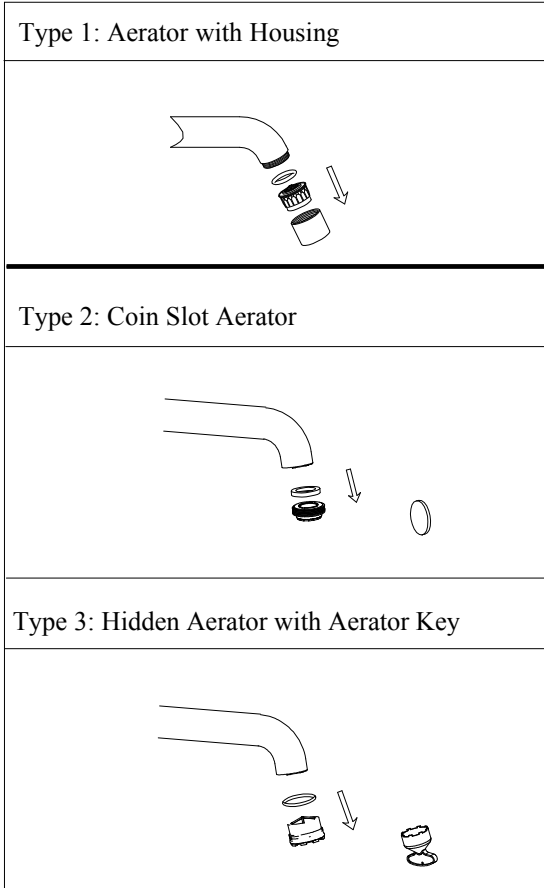

9. REPLACEMENT OF CARTRIDGE

⚠️ **CAUTION:** All water supplies must be turned off during maintenance.

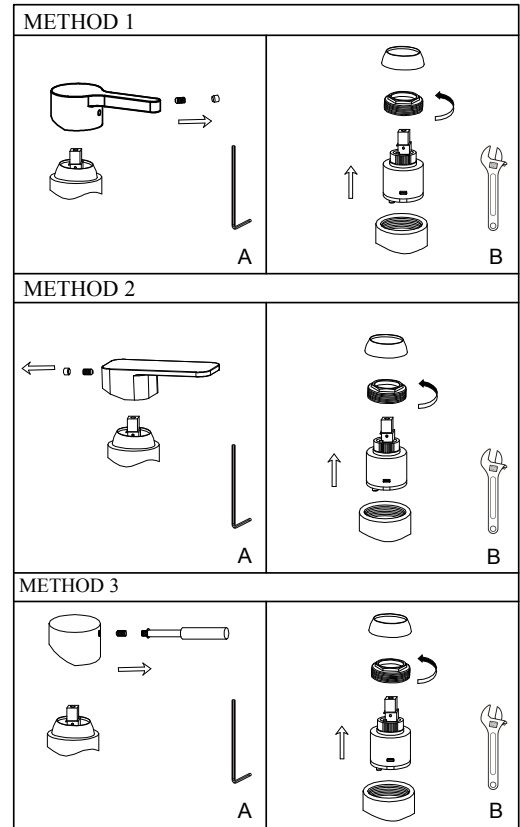

10. ⚠️ CLEANING INSTRUCTIONS

For all decorative finishes, use only a soft damp cloth to clean and shine. Use of polish, detergents, abrasive cleaners, organic solvents or acid may cause damage. Use of other than a soft damp cloth will nullify our warranty.

