

# **HOMEBASE**

## **MALIBU LED DOUBLE RING PENDANT**

### **INSTRUCTION MANUAL**

**IMPORTANT:** Please read these instructions before using the product and retain for future use.

HHGL Limited, MK9 1BA  
HHGL (ROI) Limited, D02 X576

## SAFETY AND CARE ADVICE

- For your safety, this product must be installed in accordance with local building regulations. If in any doubt, or where required by law, consult a competent person who is registered with an electrical self-certification scheme. Further information is available online or from your local authority.
- This product has been designed for non-professional, domestic use only.
- Dispose of all packaging correctly and responsibly and in accordance with all local laws and regulations. Never leave packaging components within reach of children, as they can be a source of danger.
- Do not modify or alter any product before or after installation. This may render the product unsafe.
- This is a Class 2 product and does not require an earth connection.
- This fitting must be permanently wired to the electric system.
- Always shut off the power to the circuit before starting installation.

## WARNINGS

- This product is not intended for use by persons (including children) with reduced physical, sensory and mental capabilities, or lack of experience and knowledge, unless they have been given supervision or instruction concerning the use of the product by persons responsible for their safety.
- Children should be supervised to ensure that they do not play with the product.
- Do not place this fitting in a damp atmosphere.

## CARE AND MAINTENANCE

- Always disconnect the power supply when servicing or cleaning.
- Use a clean, soft, dry or slightly damp cloth for cleaning this product.
- Do not use abrasive cloths or polishes, as this may cause damage to the product.

## LAMP INFORMATION

- This fitting is not suitable for dimming.
- The integrated LED lamps are not replaceable, when the LED lamps reach the end of their life the whole luminaire will need to be replaced.
- This fitting has a raise and fall mechanism to allow height adjustment. To shorten the fitting hold each wire in turn and gently push upwards to the desired height, the support wire will freely move into the ceiling plate. If required, the fitting can be extended back to the original height, push in the small metal release pins individually, this will release the clamp and allow each support wire to become free to extend.

## PARTS LIST

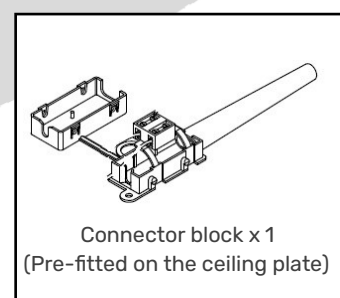
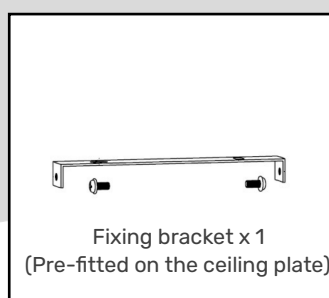
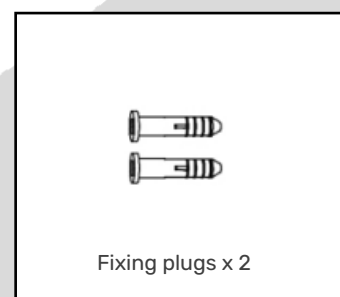
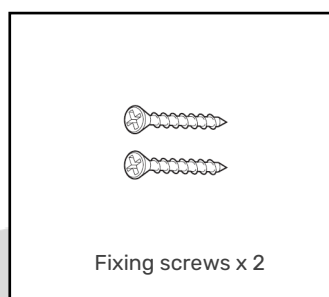
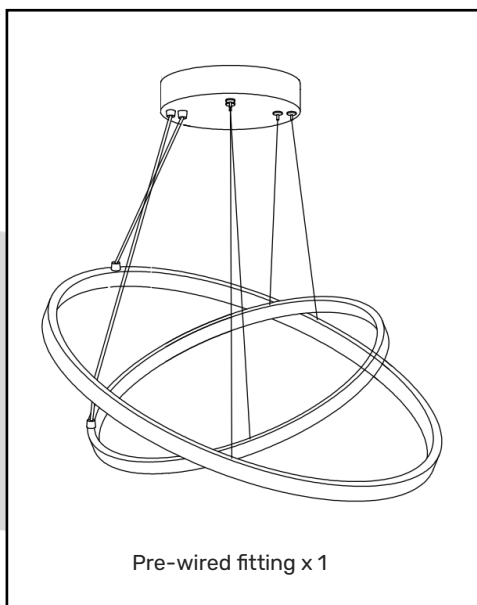

# ASSEMBLY

## Step 1

Remove the fixing bracket from the ceiling plate.

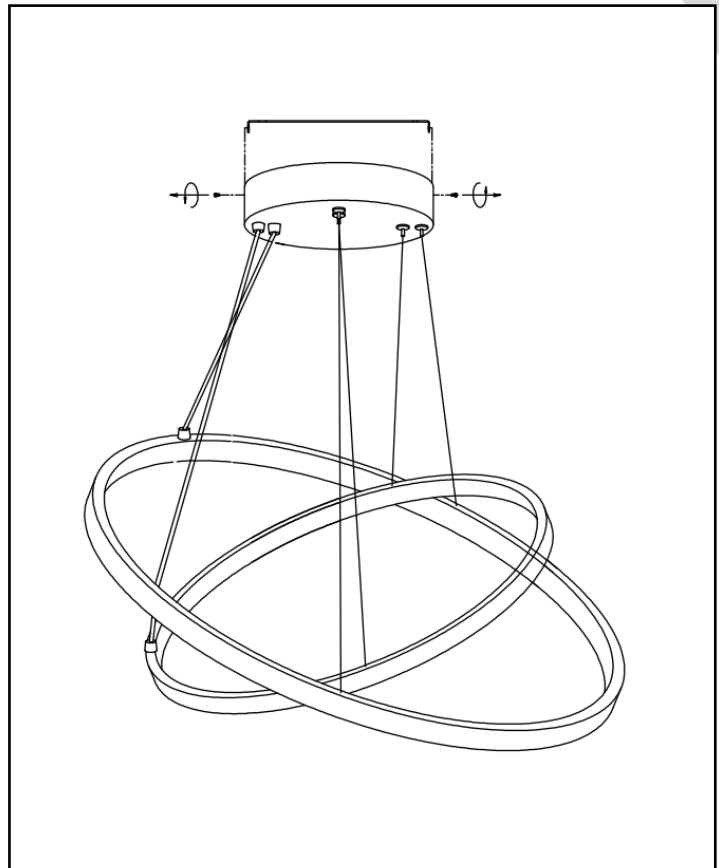

## Step 2

1. Using the fixing bracket as a template, drill suitable holes into the ceiling joist (taking care not to damage any internal wiring or pipes). Fit the suitable fixing plugs into the holes previously drilled.
2. Attach the fixing bracket to the ceiling using the fixing screws provided.

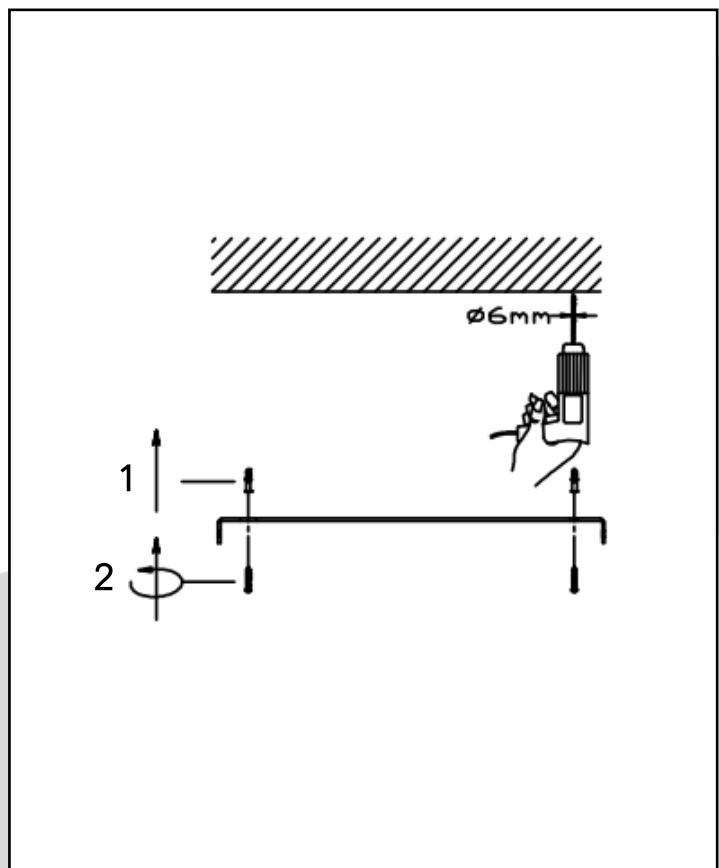

## Step 3

1. Connect the supply wires to the terminal block, opposite the corresponding wires from the fitting, see Fig. A. Note: Ensure that the connections are tight and no loose strands of wire are left out of the connector block.
2. Place the fitting over the pre-fixed bracket and screw in the side screws to secure fitting in place.

