

**HOMEBASE**

# **BERTIE BERBER OCCASIONAL CHAIR**

H72cm x W60cm x D70cm

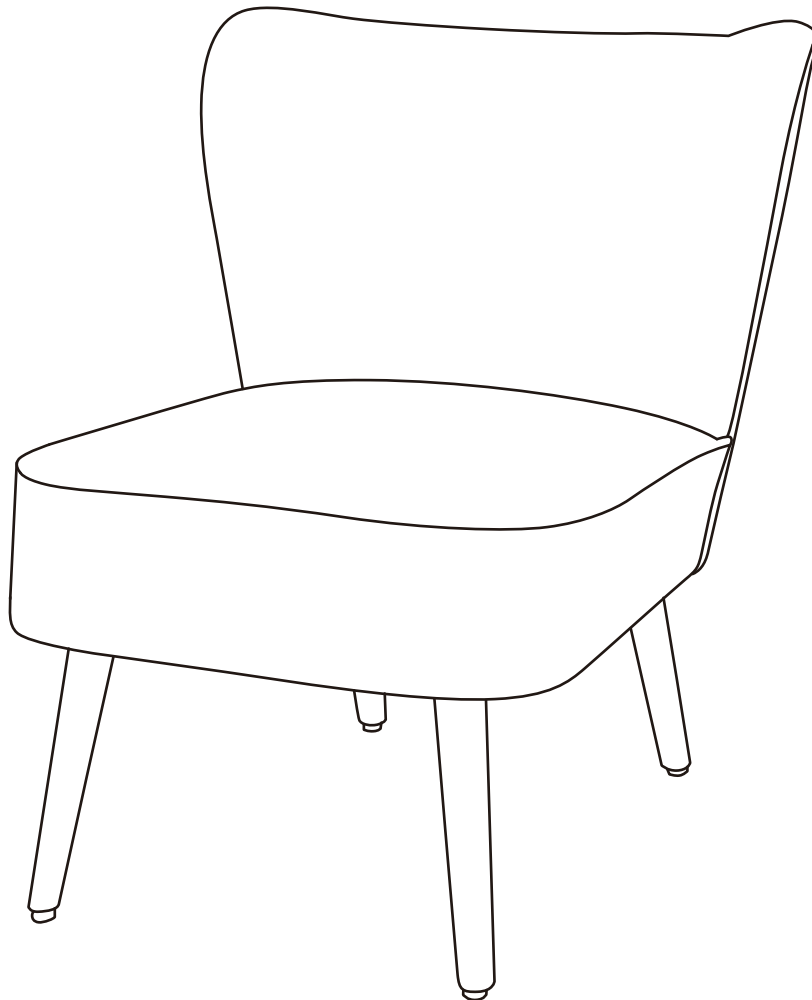

## **INSTRUCTION MANUAL**

**IMPORTANT:** Please read these instructions before using the product and retain for future use.

HHGL Limited MK9 1BA; HHGL (ROI) Limited D02 X576

# ASSEMBLY INSTRUCTIONS

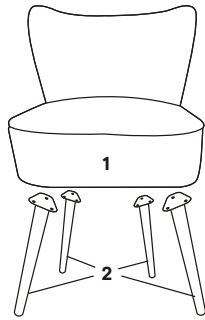



**PLEASE CHECK THAT YOU HAVE ALL THE PARTS LISTED BEFORE YOU START ASSEMBLY. IF YOU DO FIND THAT SOMETHING IS MISSING, DO NOT CONTINUE ASSEMBLY AND CONTACT YOUR LOCAL STORE.**

## Parts:

No.	Description	Qty
1	Chair body	x 1
2	Chair leg	x 4

## Fittings:

No.	Description	Qty
A	Bolts 	x 12
B	Allen key 	x 1

## Step 1

Place the Chair body (1) bottom-side up on a clean and safe surface.  
 Take the legs out of the underside of the chair.  
 Attach an individual Chair Leg (2) using Bolts (A). All legs and bolts are universal.  
 Tighten with the Allen Key (B). Do not over-tighten the Bolts.  
 Repeat the above steps for the remaining legs.  
 Turn the chair right-side up.

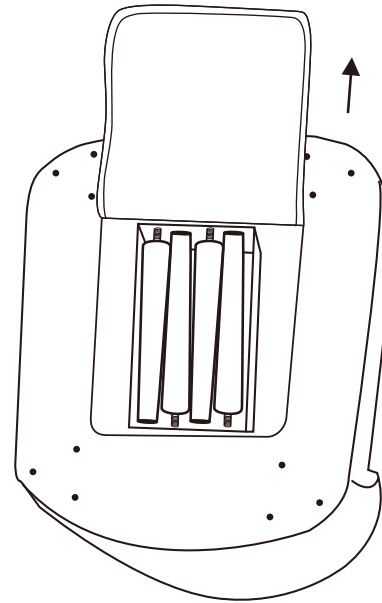

## Step 2

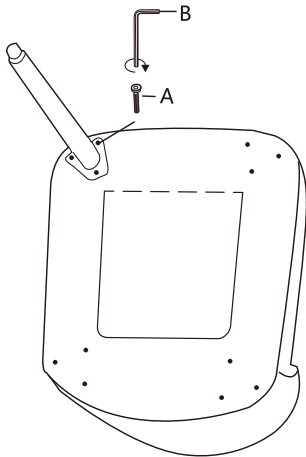

## Step 3

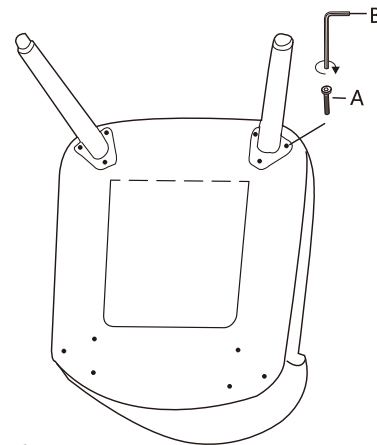

## Step 4

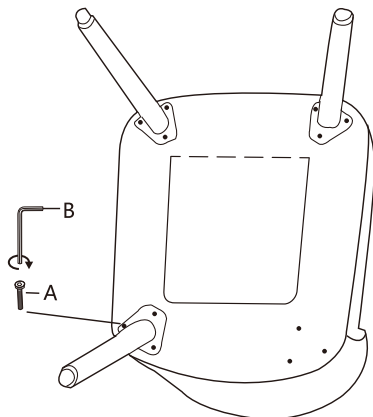

## Step 5

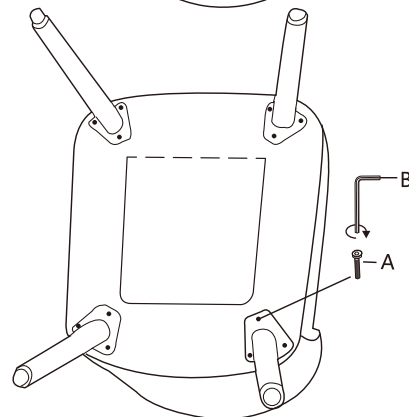

**THE USE OF POWER TOOLS TO ASSEMBLE THIS PRODUCT WILL INVALIDATE ANY WARRANTY AND MAY DAMAGE THIS PRODUCT MAKING IT UNSAFE.**

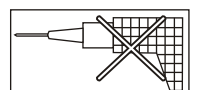

**General care:**

Over time, the fabric can become crushed and change in appearance slightly, however, there are some simple measures you can take to preserve its softness and alluring appeal.

For items of furniture that are facing heavy use, it's advisable to gently vacuum the fabric with an upholstery attachment at least once a week. Alternatively, you can also use a soft bristled brush or clothes brush. Always blot spills immediately with a clean cloth by dabbing the area gently.

Some fabrics are prone to marking, so be mindful not to leave anything heavy resting on your furniture for too long as this can cause marks and dents.