

# HARTINGTON

MORTIMER COLLECTION

## Table

Powder-coated aluminium frame

Hand woven synthetic rattan

Toughened glass table top

H67/45 x W148 x D88cm



### Important

Please read these instructions before using the product. Retain instructions for future use.

HHGL Limited, MK9 1BA HHGL (ROI) Limited, D02 X576

## **SAFETY & CARE ADVICE**

Please read these instructions fully before starting assembly.



- This product is made from toughened glass, which is strong but not unbreakable. In the unlikely event that the glass fails, it will break into a large number of small fragments that may be spread over a wide area. This is a feature of toughened glass and is designed to remove the risk of injury from glass breaking into large shards.
- If the glass is chipped or broken, stop using the product.
- Tables should not be dragged at any time.
- Do not strike the glass with hard or pointed items, or place heavy weight on the table.
- Do not place hot items directly onto the glass.
- Avoid dropping objects on the glass, as this may weaken or shatter it.
- Do not use the glass as a chopping surface.
- Check you have all the components and tools listed in this booklet before assembly.
- Remove all fittings from their plastic bags and separate them into their groups.
- Keep children and animals away from the work area; small parts could choke if swallowed.
- Make sure you have enough space to lay out the parts before starting.
- Do not stand or put weight on the component parts during assembly, as this could cause damage.
- Assemble on a soft, level surface to avoid damaging the unit or your floor.
- We recommend a two-person assembly.
- Dispose of all packaging carefully and responsibly.

## **IMPORTANT INFORMATION**

- Regularly check all the bolts, screws and fastenings are secure.
- Only clean using a damp cloth and mild detergent; do not use bleach or abrasive cleaners.

## COMPONENTS - PANELS

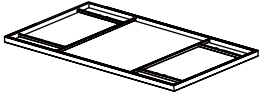
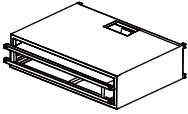
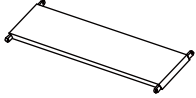

Please check you have all components listed below. If you have any missing or damaged components, please contact your local store.

A	 Table rim	1
B	 Table leg	2
C	 Support bar	1
D	 Table glass	1

## COMPONENTS - FITTINGS

Please check you have all fittings listed below. If you have any missing or damaged fittings, please contact your local store.

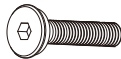
**Note:** The quantities below are the correct amount to complete the assembly. In some cases, more fittings may be supplied than required.

E	 Screw M6x25	12
F	 Washer	12
G	 Screw cap	12

## Tools included

H	 Allen key	1
---	--	---

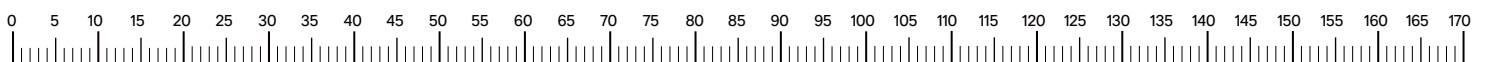

# ASSEMBLY INSTRUCTIONS

## Step 1

Use screws **E**, washers **F** and screw caps **G** to fix the table legs **B** to the table rim **A**. Repeat this step until another leg is assembled. Do not fully tighten all screws until assembly is completed.

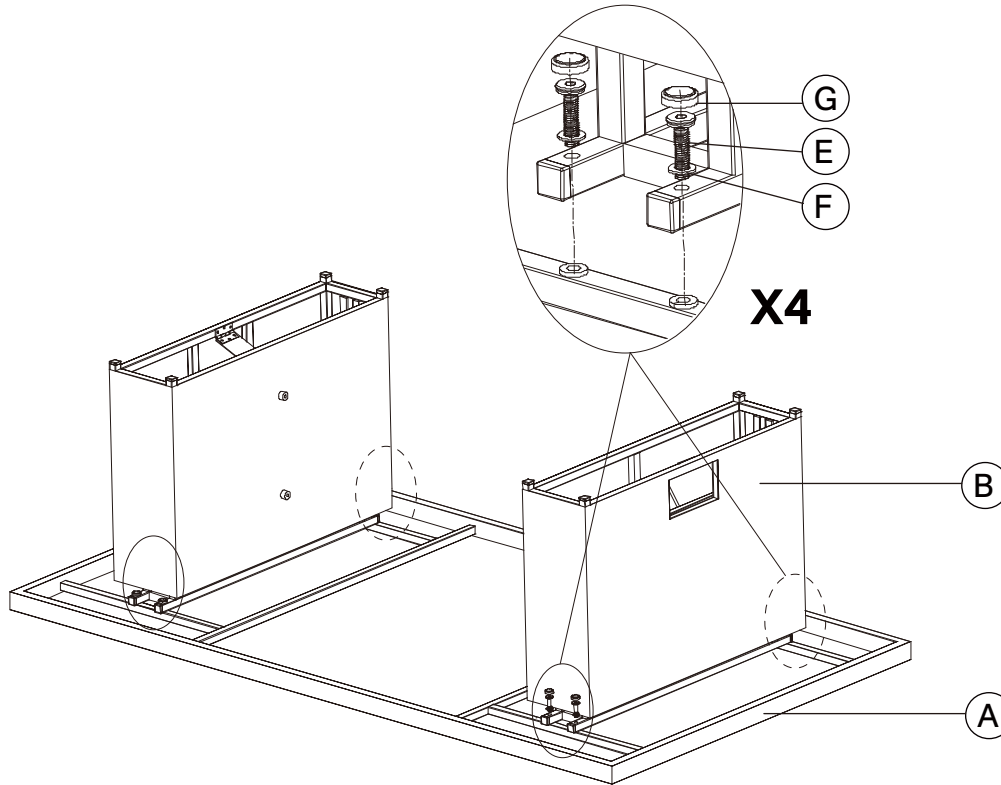

## Step 2

Use screws **E**, washers **F** and screw caps **G** to fix the support bar **C** to the unit. Do not fully tighten all screws until assembly is completed.

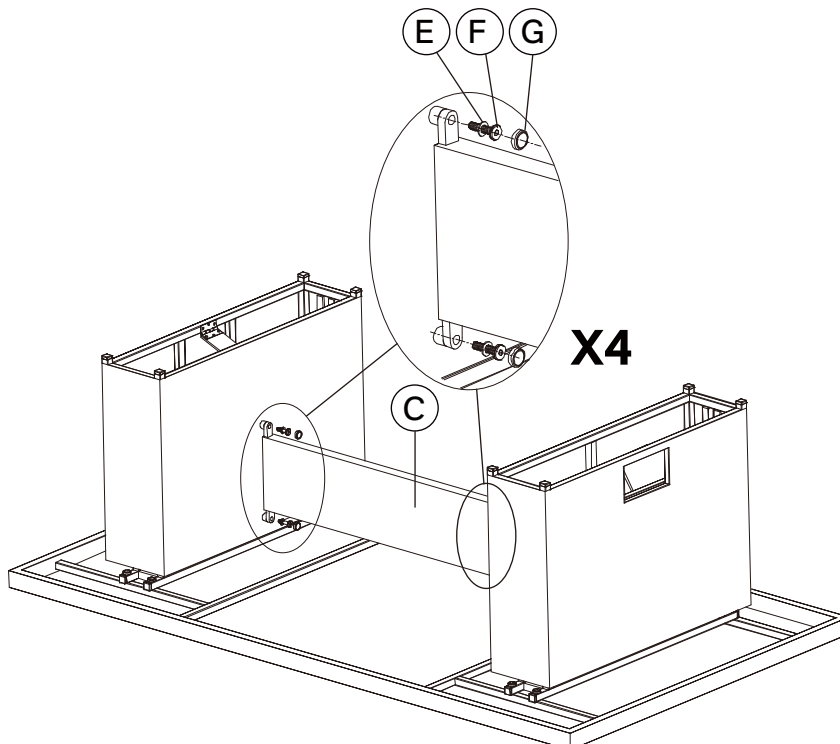

### Step 3

Carefully place the table glass **D** onto the table rim.

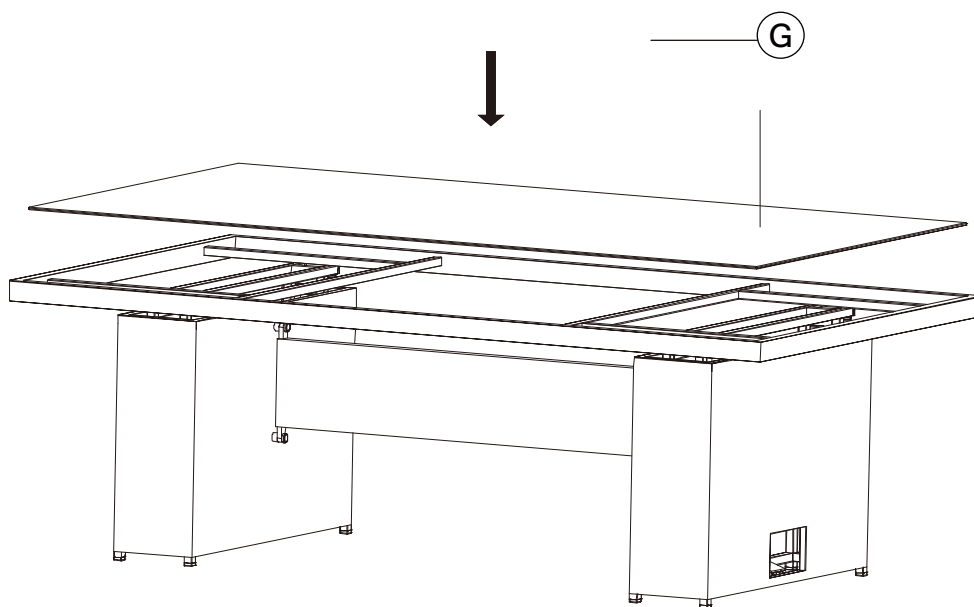

### Step 4

Your table is now ready to use.

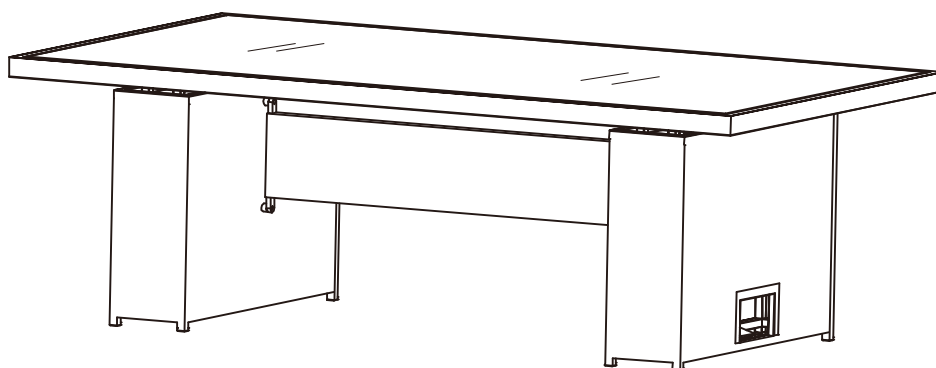

**ASSEMBLY COMPLETE**

## RISING TABLE FUNCTION ILLUSTRATION

UP

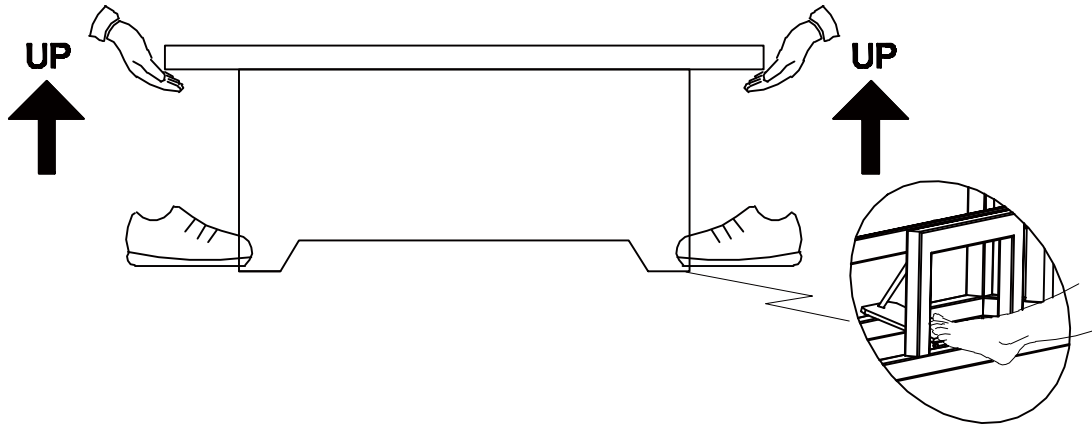

Just step on the rim at the bottom of the table (do not touch the pedal).

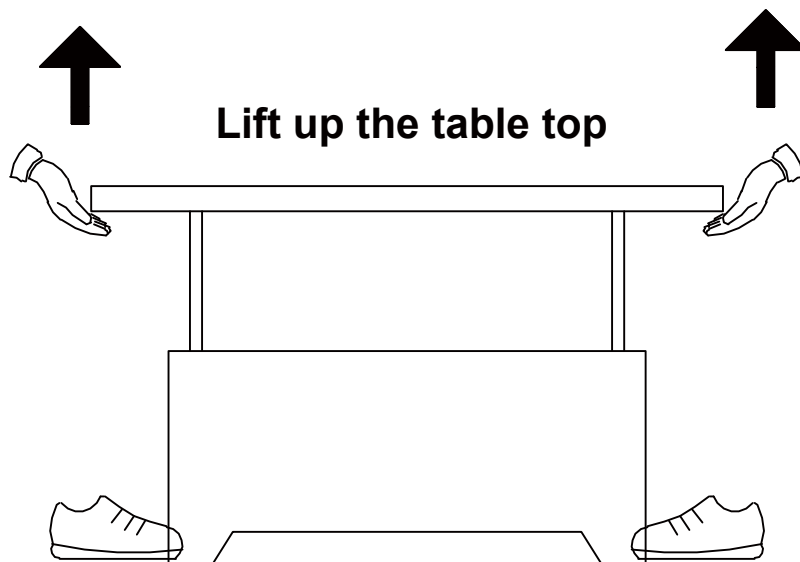

Lift the table top up until a 'click' is heard, then the table raising process is complete.

# RISING TABLE FUNCTION ILLUSTRATION

**DOWN**

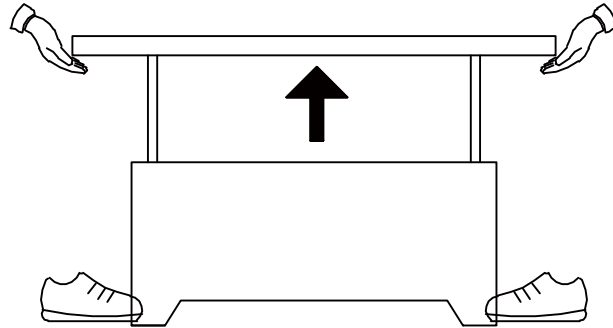

**Just step on the rim at the bottom of the table  
(do not touch the pedal) and lift the table top slightly.**

**To lower the table top**

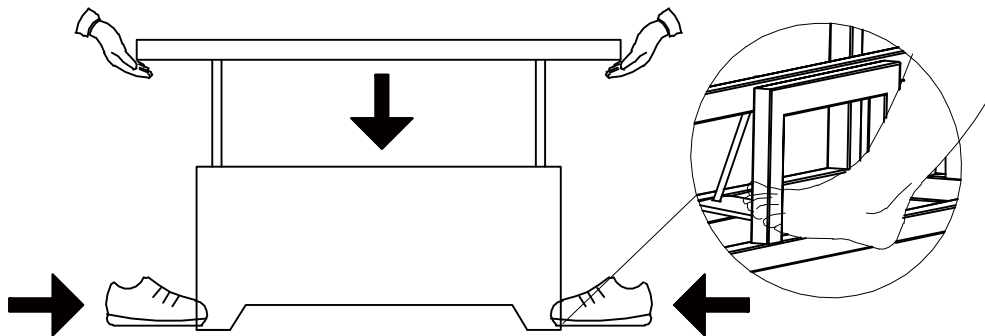

**Move the feet onto the pedal and press down.  
Slowly let down the table top.**

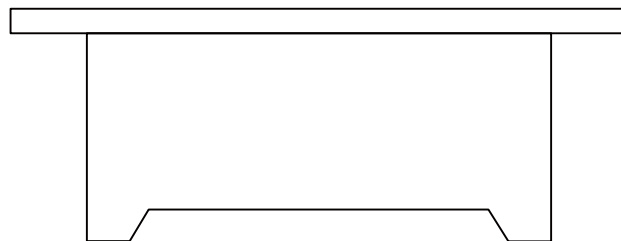

**The process is complete.**