

SOVEREIGN

EASY GARDENING

18V CORDLESS LAWN MOWER

Article No. 555376

Model No. LM 32H



Technical Support & Parts

01904 727509

Mon-Fri 9am-5pm Sat-Sun 11am-4pm
www.coreservice.co.uk

ORIGINAL INSTRUCTION MANUAL

Please read these instructions fully before starting assembly.

HHGL Limited, MK9 1BA; HHGL (ROI) Limited, D02 X576

July 21

CONTENTS

| | |
|---------------------------|----|
| General safety warnings | 3 |
| Intended use | 12 |
| Warning symbols | 13 |
| In the box | 17 |
| Assembling the lawn mower | 18 |
| Operating the lawn mower | 25 |
| Maintenance and storage | 29 |
| Troubleshooting | 32 |
| Technical data | 34 |
| Recycling and disposal | 35 |
| Getting help | 35 |
| Warranty | 36 |

GENERAL SAFETY WARNINGS

Safety Warnings



WARNING! Read all safety warnings and instructions.

Failure to follow the warnings and instructions may result in electric shock, fire and/or serious injury.



WARNING! Read all safety warnings and instructions designated by the  symbol. Save all warnings and instructions for future reference.

- This appliance is not intended for use by persons (including children) with reduced physical, sensory or mental capabilities, or lack of experience and knowledge, unless they have been given supervision or instruction concerning use of the appliance by a person responsible for their safety.
- Perform assembly operations as described in this manual. Failure to observe this warning may lead to serious injury, death, or damage to the lawn mower.
- Children should be supervised to ensure that they do not play with the product.

IMPORTANT

READ CAREFULLY BEFORE USE & KEEP FOR FUTURE REFERENCE

GENERAL POWER TOOL SAFETY WARNINGS

Training

- **Read the instructions carefully and make sure you fully understand them.** Make sure you are familiar with the controls and the correct use of the product.
- **Never allow children or people unfamiliar with these instructions to use the product.** Local regulations can restrict the age of the operator.
- **Never operate the product while people, especially children or pets, are nearby.**
- **Keep in mind that the operator or user is responsible for any accidents or hazards occurring to other people or their property.**

Preparation

- **While operating the product, always wear substantial footwear and long trousers.** Do not operate this product when barefoot or wearing open-toed sandals. Avoid wearing clothing that is loose fitting or has hanging cords or ties.
- **Thoroughly inspect the area where the product is to be used and remove all objects which could be thrown by the product.**
- **Before using, always visually inspect to see that the blade, blade bolt and the blade assembly are not worn or damaged.** Replace worn or damaged components in sets to preserve balance. Replace any damaged or unreadable labels.

- **Ensure the switch is in the 'off' position before inserting the battery pack.** Inserting the battery pack into a machine that is switched on can result in injury.

General Operation

- Use the tool only with specifically designated battery packs. Use of any other battery packs will increase the risk of injury and fire.
- Only operate the product in daylight or in good artificial light.
- Do not expose the tool and charger to rain or wet conditions. If a tool or charger is exposed to moisture it will increase the risk of electric shock.
- Avoid operating the product on wet grass.
- Always be sure of your footing on slopes.
- Walk, never run.
- Mow across the face of slopes, never up and down.
- Exercise extreme caution when changing direction on slopes.
- Do not mow excessively steep slopes.
- Use extreme caution when reversing or pulling the product towards you.
- Stop the blades if the product has to be tilted for transportation, when crossing surfaces other than grass, and when transporting the product to and from the area to be mowed.

- Never operate the product with defective guards or shields or without safety devices in place, such as deflectors or grass collector.
- When switching on the motor, keep feet well away from the blades.
- Do not tilt the product when switching on the motor, except if the product has to be tilted for starting. In this case, do not tilt it more than absolutely necessary and lift only the part furthest away from the operator.
- Do not start the product when standing in front of the discharge opening.
- Do not put hands or feet near or under rotating parts.
- Keep clear of the discharge opening at all times.
- Do not transport the product while the cutting blade is running.
- Stop the product and remove the key/battery pack from the machine and make sure that all moving parts have come to a complete stop:
 - Whenever you leave the product unattended.
 - Before clearing blockages or unclogging the chute.
 - Before checking, cleaning or working on the product.
 - After striking a foreign object, be sure to inspect the product for damage and make repairs before restarting and operating the product.

- If the product starts to vibrate abnormally:
 - Inspect for any damages.
 - Replace or repair any damaged parts.
 - Check for and tighten any loose parts.

Chargers

- This appliance can be used by children aged from 8 years and above and persons with reduced physical, sensory or mental capabilities or lack of experience and knowledge if they have been given supervision or instruction concerning use of the appliance in a safe way and understand the hazards involved.
- Children shall not play with the appliance. Cleaning and user maintenance shall not be made by children without supervision.
- If the supply cord is damaged, it must be replaced by the manufacturer, its service agent or similarly qualified persons in order to avoid a hazard.
- Recharge only with the charger specified by the manufacturer. Do not use the original charger on other li-ion batteries or on any other type of battery, as this can increase the risk of fire or explosion.
- Check the battery charger, cable and plug before each use. Do not use the battery charger if damaged. Do not open the battery charger yourself; the charger must be repaired by qualified personnel using original spare parts.

- The charger is designed to use a standard household 230-240 V~ 50/60HZ power source; ensure that the plug matches the outlet.
- Never modify the plug in any way, this will reduce the risk of electric shock.
- Do not abuse the cord of the charger. Never use the cord for carrying, pulling or unplugging the charger. Keep the cord away from heat, oil, sharp edges or moving parts. Damaged or entangled cords increase the risk of electric shock.
- Make sure the charger cord is situated so that it will not be stepped on, tripped over or get damaged.
- Keep the battery charger clean. Contamination can increase the risk of electric shock.
- The charger is for indoor use only, do not expose to rain. Protect the battery charger from rain and moisture. If water accesses the battery charger there is an increased risk of electric shock.
- The battery will heat up whilst charging. To reduce the risk of fire, do not operate the battery charger on flammable surfaces, such as paper or textiles.
- The temperature range over which the battery pack can be charged is typically between 5°C-45°C. Attempts to charge outside of the prescribed temperature range may automatically be blocked by the protection circuitry of the battery pack. Longest life and best performance can be obtained if the battery pack is charged at room temperature.

- Disconnect the charger from the power supply when not in use. This will reduce the risk of electric shock or damage to the charger.
- If the supply cord is damaged, it must be replaced by the manufacturer, its service agent or similarly qualified persons in order to avoid a hazard.
- Do not short out the contacts of the battery or charger.
- Respect the polarity "+/-" when charging.
- Do not open the unit and keep out of the reach of children.
- Do not charge the batteries of other manufactures or ill-suited models.
- Ensure that the connection between the battery charger and battery is correctly positioned and is not obstructed by foreign bodies.
- Keep battery charger's slots are free of foreign objects and protect against dirt and humidity. Store in a dry and frost-free place.
- When charging batteries, ensure that the battery charger is in a well-ventilated area and away from inflammable materials. Batteries can get hot during charging. Do not overcharge any batteries. Ensure that batteries and chargers are not left unsupervised during charging.

Battery pack

- Fully charge the battery pack before first use.
- Recharge the battery pack immediately when the power output starts to slow. DO NOT CONTINUE TO USE THE PRODUCT WHEN THE BATTERY LEVEL IS LOW.
- To prevent serious damage to the battery, charge in temperatures above 5°C or below 45°C. Longest life and best performance can be achieved when the battery is charged at room temperature.
- If the battery temperature is above 45°C it must be allowed to cool before putting it into the charging station.
- To reduce the risk of explosion, ensure the battery pack is not left in the sun for extended periods of time and that it is kept away from fire.
- Do not carry individual battery packs in your pockets or bag, as they could short circuit against other metal items.
- Should a li-ion battery catch fire, be sure to use the correct fire extinguisher to combat the fire. DO NOT THROW WATER ON A BURNING LI-ION BATTERY.
- If the battery pack becomes too hot during charging, disconnect and switch off immediately. Contact the service centre directly.
- Do not attempt to open the battery yourself.

- When the battery pack is not in use keep it away from other metal objects, such as paperclips, coins, keys, nails, screws or other small metal objects that can make a connection from one terminal to another.
- Do not dismantle, open or shred cells or battery pack.

Maintenance and storage

- Keep all nuts, bolts and screws tight to be sure the product is in a safe working condition.
- Check the grass collector frequently for wear or deterioration.
- Be careful when adjusting the product to prevent trapping fingers between moving blades or other fixed parts of the product.
- Always allow the product to cool down before storing.
- When servicing the blades, be aware that even though the power source is switched off, the blades can still move.
- Replace worn or damaged parts for safety. Use only genuine replacement parts and accessories.
- DO NOT attempt to open the charger and battery pack. There are no customer-serviceable parts inside. Return to any authorised service centre.
- Store the appliance with the battery pack fully charged at room temperature (around 20°C).

- Every deep discharge cycle decreases the capacity of the battery pack. To prolong battery life, it is recommended that you charge the battery every six months, within extended periods of time when the product is not in use.

Servicing

- Have your tool repaired by an authorised service agent. This tool is manufactured in accordance with the relevant safety regulations. To avoid danger, equipment must only be repaired by qualified technicians.
- Only use parts and accessories made for this machine by the manufacturer. Failure to do so can result in personal injury.

INTENDED USE

This lawn mower has been designed for cutting grass. The machine is to be used only for its prescribed purpose, and any other use is deemed to be a case of misuse.

PLEASE NOTE: Our equipment has not been designed for use in commercial, trade or industrial applications. Our warranty will be voided if the machine is used in commercial, trade or industrial businesses or for equivalent purposes.

WARNING SYMBOLS

Safety symbols

The purpose of safety symbols is to attract your attention to any possible dangers. The safety symbols and their explanations require your careful attention and full understanding. The symbol warnings do not, by themselves, eliminate any danger. The instructions and warnings they give are no substitute for proper accident prevention measures.



WARNING: Be sure to read and understand all safety instructions within this operator's manual, including all safety alert symbols such as '**DANGER**', '**WARNING**', and '**CAUTION**' before using this tool. Failure to follow all instructions listed below may result in electric shock, fire and/or serious personal injury.

SAFETY ALERT SYMBOLS: Indicate **DANGER**, **WARNING**, or **CAUTION** and may be used in conjunction with other symbols or pictographs.

Symbol meanings

This page depicts and describes safety symbols that may appear on this product. Read, fully understand and follow all instructions on the machine before attempting to assemble and operate.



To reduce the risk of injury, the user must read this instruction manual carefully.

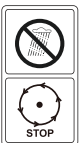

Avoid using the tool in the rain.

Blade continues to rotate after the machine is switched off. Wait until all machine components have completely stopped before touching them.



Keep bystanders away. Objects thrown by the product could hit the user or other bystanders. Always ensure that other people and pets remain at a safe distance from the product when it is in operation.



Beware of sharp blades. Blades continue to rotate after the motor is switched off. Remove the safety key before performing any maintenance tasks.



Guaranteed sound power level value is 90 dB.



Wear ear protection, eye protection and gloves (PPE) when using the product.



WEEE symbol. Waste electrical products should not be disposed of with household waste. Please recycle where facilities exist. Check with your local authority or local store for recycling guidelines.



The product complies with the applicable European Directives, and an evaluation method of conformity for these directives was done.



The product complies with the applicable UK Directives, and an evaluation method of conformity for these directives was done.

Warning symbols on the battery pack



To reduce the risk of injury, the user must read this instruction manual carefully.



Do not throw into water.



Do not throw on fire.



Do not subject the battery to strong sunlight over long periods of time. Do not leave on a heater (max. 45°C).



Batteries contain Li-ion. Do not dispose of waste batteries in domestic waste. Contact your local authority to find out how to dispose of batteries.



The product complies with the applicable European Directives, and an evaluation method of conformity for these directives was done.



The product complies with the applicable UK Directives, and an evaluation method of conformity for these directives was done.



Pole orientation.

Warning symbols on the charger



To reduce the risk of injury, the user must read this instruction manual carefully.



Indoor use only.



Class II equipment.

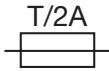

Fuse T 2A time lag fuse with rated current of 2A.



Pole orientation.



WEEE symbol. Waste electrical products should not be disposed of with household waste. Please recycle where facilities exist. Check with your local authority or local store for recycling advice.



The product complies with the applicable European Directives, and an evaluation method of conformity for these directives was done.



The product complies with the applicable UK Directives, and an evaluation method of conformity for these directives was done.

IN THE BOX

Parts

- | | |
|-------------------------------|-----------------------|
| 1. Upper handle | 7. Carry handle |
| 2. Switch box | 8. Rotating knobs x 2 |
| 3. Lock-off button | 9. Start lever |
| 4. Cable clips x 2 | 10. Battery pack |
| 5. Grass bag | 11. Charger |
| 6. Battery pack locating tank | 12. Charger plug |

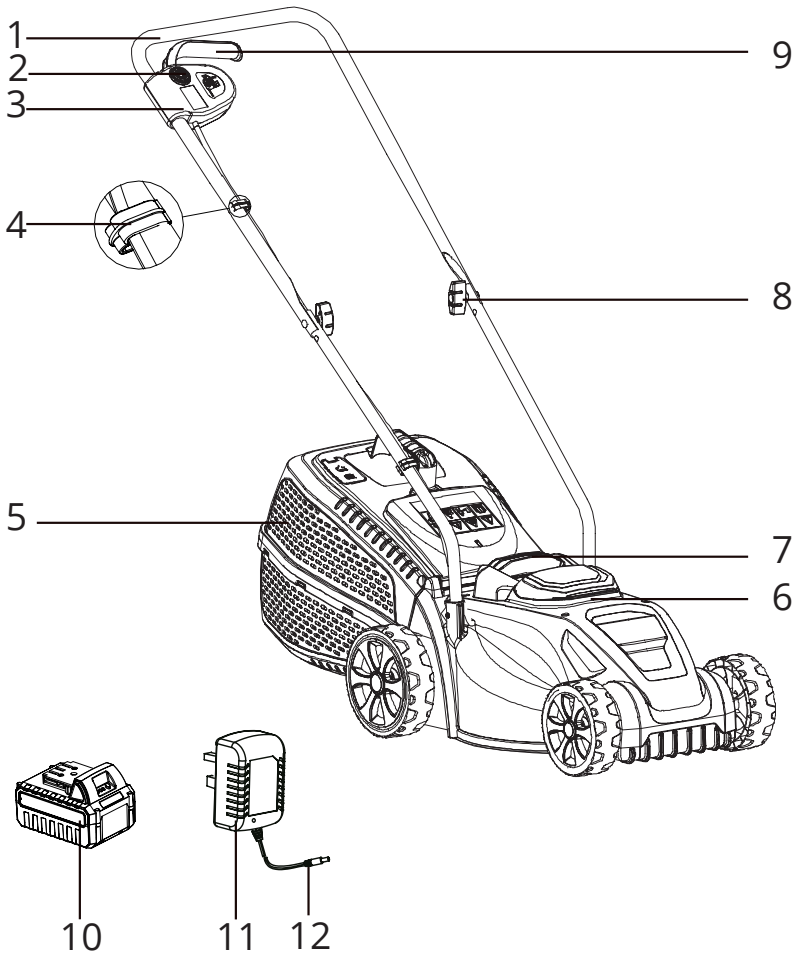

ASSEMBLING THE LAWN MOWER

Assemble the lower brace

1. Insert the lower brace into the slot on the mower deck.
2. Use two installation screws to fix the lower brace.

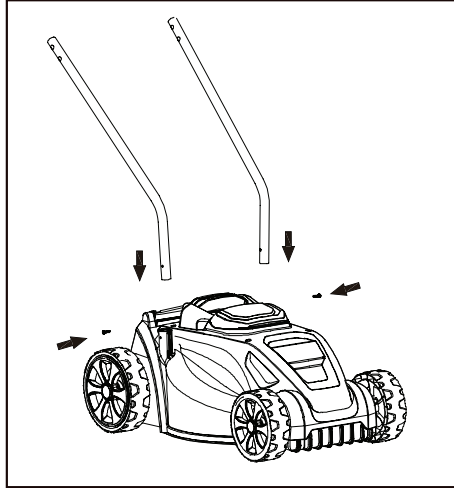

Attach the top handle to lower brace

Mount the top handle to the lower brace using the two rotating knobs.

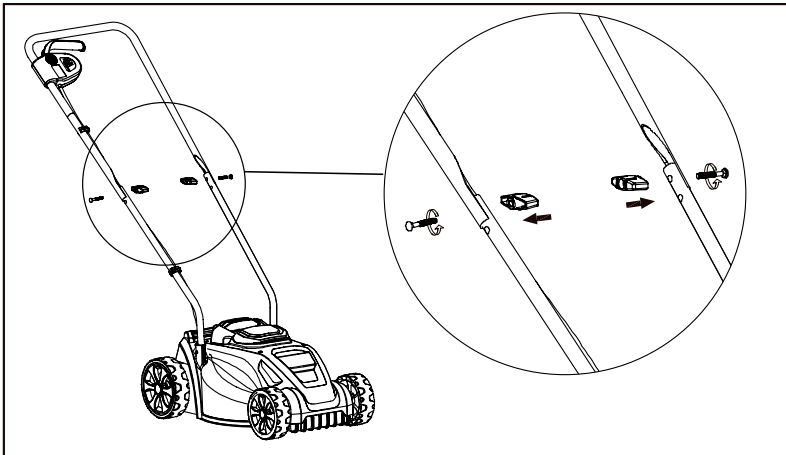

Fitting the cable clip

Ensure that the cable clips supplied are used to fix the cable to the lower brace.

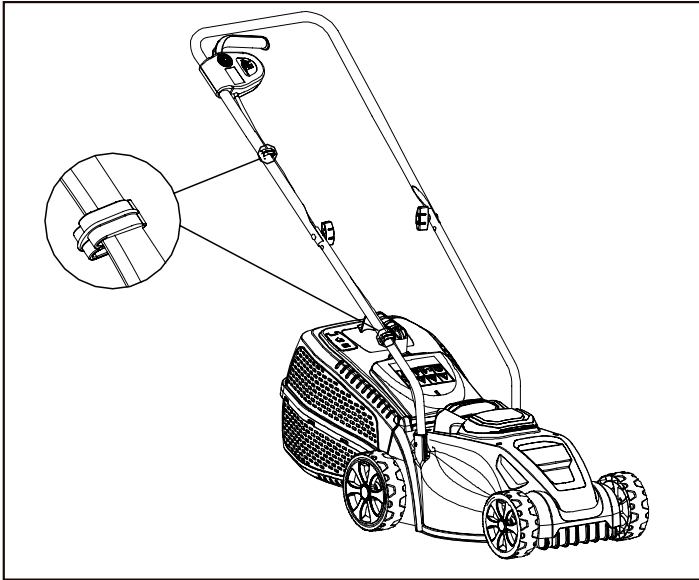

Mounting the grass catcher

1. Fit the upper part onto the lower part by fixing all the outer clips correctly.

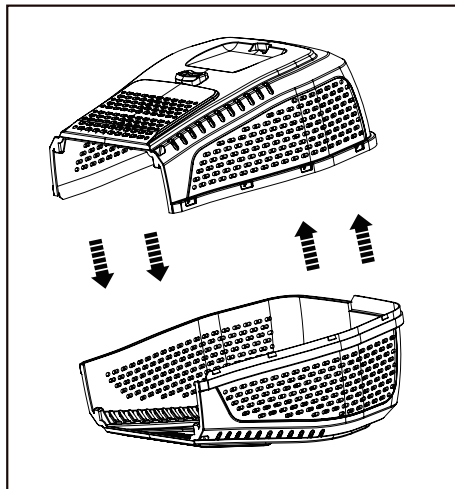

2. Fit the handle onto the top of the grass catcher so that it clicks into place.

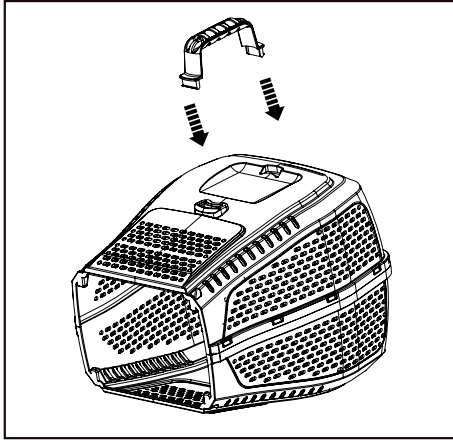

3. Lift the safety flap, and hang the grass box on the hook. Fold the safety flap onto the grass box.

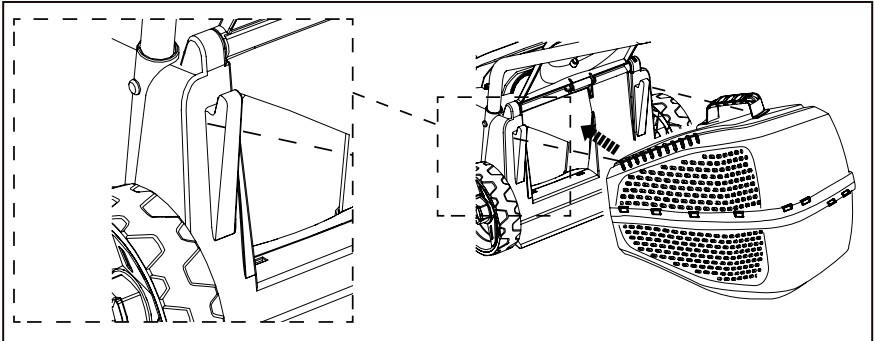

REMOVING AND INSERTING THE BATTERY PACK

Insert the battery pack

Push the battery pack into the tank until you hear a click. This means the battery pack has been locked in position; close the battery pack tank cover.

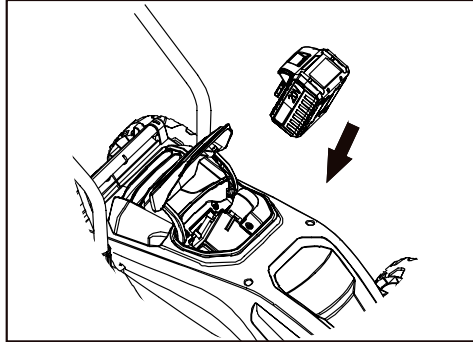

NOTICE:

Make sure that the latch on the mower snaps into place and that the battery pack is secured to the mower before starting operation.

Removing the battery pack from the tool

Open the battery pack tank cover. Push the battery pack release button, and the battery pack will come out automatically.

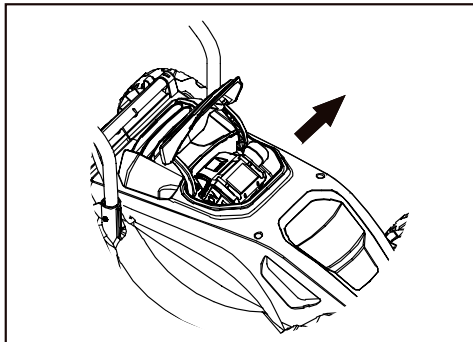

NOTE: Safety key

This lawn mower is fitted with a safety key, this prevents the accidental start up of your cordless lawn mower.

The safety key has been designed to totally disable the lawn mower when it is removed.

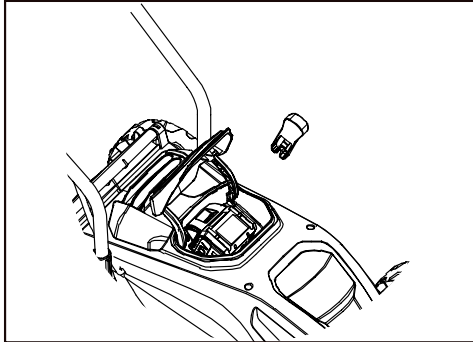

CHECKING THE BATTERY CAPACITY

Push the power indicator button, and the remaining percentage of battery capacity will show on screen.

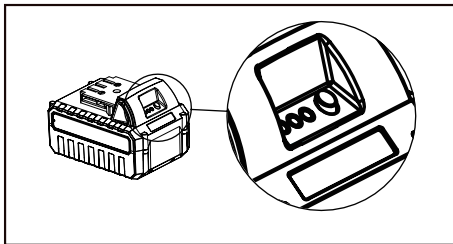

Charging the battery



WARNING!

The charger and battery pack are specifically designed to work together so do not attempt to use any other devices. Never insert or allow metallic objects into your charger or battery pack connections because an electrical failure and hazard will occur.

CHARGING PROCEDURE

1. Plug the charger into an appropriate power supply. When connected, there will be a green LED light.
2. Insert the charger plug (12) into the charging hole (A1) in battery pack (10), make sure the plug is fully in position. The light on the charger will turn red and the three green LED lights on the battery pack will flash alternately.
3. The battery pack will be fully charged in 2.5hrs. When fully charged, the LED light on the charger will turn green and the three LED lights on the battery pack will stop flashing and stay green.

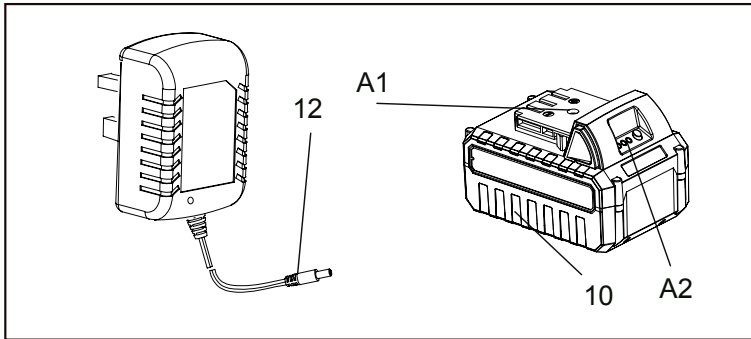

Important charging notes

Longest life and best performance can be obtained if the battery pack is charged when the air temperature is between 18-24°C. Do not charge the battery pack in a very low or very high air temperature. This is important and will prevent serious damage to the battery pack.

1. When using your tool continuously, the batteries in your battery pack will become hot. You should let a hot battery pack cool down for approximately 30 minutes before attempting to recharge.
2. The charger and battery pack may become warm to touch while charging. This is a normal condition and does not indicate a problem.

3. Use the charger in normal room temperatures whenever possible. To prevent overheating, do not cover the charger and do not charge battery packs in direct sunlight or near heat sources.
4. If the battery pack does not charge properly:
 - (1) Check the main socket by plugging in a lamp or other appliance.
 - (2) Move the charger and battery pack to a location where the surrounding air temperature is approximately 18-24°C.
 - (3) If charging problems persist, take or send the tool, battery pack and charger to your local service centre.
5. The battery pack should be recharged when it fails to produce sufficient power on jobs which were easily done previously. DO NOT CONTINUE to use under these conditions. Follow the charging procedure. You may also charge a partially used pack whenever you desire with no adverse effect on the battery pack.
6. Under certain conditions, with the charger plugged in to the power supply, the exposed charging contacts inside the charger can be shorted by foreign material. Foreign materials of a conductive nature, such as, but not limited to, steel wool, aluminium foil, or any buildup of metallic particles, should be kept away from charger cavities. Always unplug the charger from the power supply when there is no battery pack in the cavity. Unplug the charger before attempting to clean it.
7. Do not immerse the charger in water or any other liquid.



WARNING!

Don't allow any liquid to get inside the charger; electric shocks may result. To facilitate the cooling of the battery pack after use, avoid placing the charger or battery pack in a warm environment, such as in a metal shed, or an un-insulated trailer.



WARNING!

Never attempt to open the battery pack for any reason. If the plastic housing of the battery pack breaks or cracks, return to a service centre for recycling; do not put it into further use.

OPERATING THE LAWN MOWER



NOTE: This battery pack has been shipped in a low charge condition. It should be fully charged before first use. Make sure the mains voltage is the same as the rating label, which is located on the charger.



WARNING!

The machine is intended for use by adults. Children or other people who are unfamiliar with the operating instructions must not use the machine. The operator or user is responsible for any accidents or damage to other persons or their property.

CUTTING HEIGHT ADJUSTMENT

Adjust the cutting height according to the needs of your lawn. The cutting height depends on the kind of lawn and its actual height. When mowing high grass, start with the maximum cutting height and make a second cut with a lower cutting height.

1. Release the start lever and disconnect the battery pack from the mower.
2. Pull the rear and front shaft out and place them into the correct slot for the desired cutting height.
3. Make sure that the rear and front shaft are at the same level.



NOTE! Always ensure the lever clicks back into the slot.

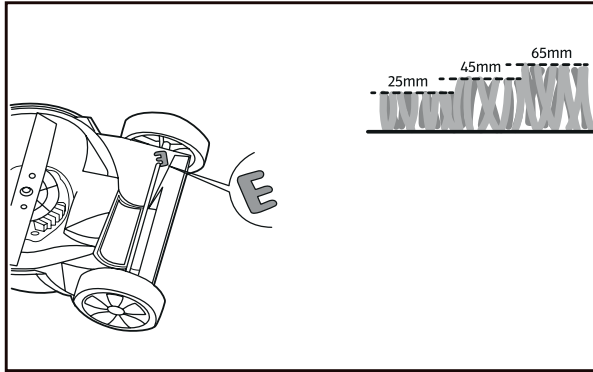

Switching on/off

1. Ensure the start lever is released. Insert the safety key.
2. To switch on, press the lock-off button, and squeeze the start lever towards the handle, release the lock-off button
3. To switch off, release the start lever.

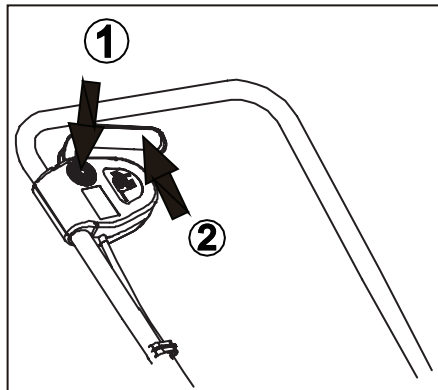

NOTE: Do not continue to press the start button after an automatic shut-off of the machine, as this will result in battery damage.



WARNING: When the motor has been switched off, the blade will continue to run for several seconds. Do not touch the underside of the mower until the cutter has come to a complete standstill.

Working with the Lawn mower

Regular mowing encourages increased foliation of the grass and kills off weeds at the same time.

Therefore, not only does each mowing increase the density of the lawn, it also produces an evenly resilient lawn, The first cut is to be made in around April, at a growth height of 70~80mm. In the main vegetation period, the lawn is to be mowed at least once a week.

- Run the equipment at a walking pace, in tracks that are as even as possible. For gap-free mowing, the tracks should always overlap by a few centimetres.
- Watch for holes, ruts, rocks, hidden objects or bumps which could cause you to slip or trip. Tall grass can hide obstacles, Be aware of footing when mowing near drops, ditches and embankments.
- Avoid mowing wet grass. There is a fall risk. Adjust the cut height so the equipment is not overloaded. Otherwise, the motor may be damaged.
- On slopes, always work across the slope. Take particular care when going backwards and pulling the equipment. never up and down. Take care when changing direction on a slope. Never mow slopes greater than 15°.
- Clean the equipment after each use, as described in the chapter on “ Maintenance and Storage”.

Mower overload protection

To avoid overloading the machine, do not mow an area larger than that recommended by the manufacturer for this machine. This mower has built-in overload circuit protection. When the mower is overloaded, the motor will stop. Switch the mower off and check to see if grass has collected beneath the deck and clear it if necessary, then restart the mower.

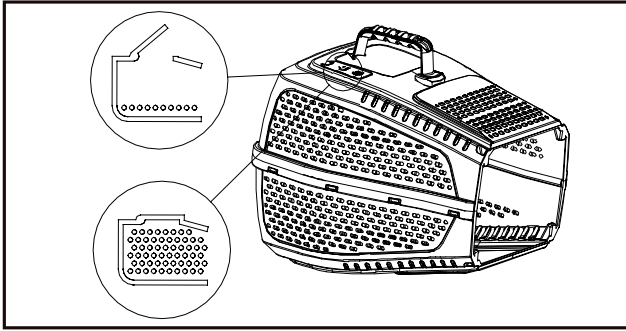

Function of full indicator

If the grass bag is empty or it is not filled with grass, the grass full indicator will be open. If the grass bag is filled with grass the grass full indicator will be closed.

Emptying the grass bag

When the grass bag indicator closes, this is a sign that you should empty the grass bag.



NOTE: Before taking off the grass bag, switch off the mower and wait until the blade has come to a complete stop.

To take off the grass bag, use one hand to lift up the safety flap and the other to grab onto the carry handle. The safety flap automatically falls down after removing the grass bag and closes off the rear chute opening.

Empty out the grass bag then refit to the machine.



NOTE: If any grass residue is caught in the discharge chute, clean it using a brush. Do not remove grass debris from the mower casing or the blade by hand or with your feet. Instead use suitable tools, such as a brush or broom. To ensure that the cut grass can be collected into the grass bag, the discharge opening and inside the mower casing must be cleared of any blockages.

MAINTENANCE AND STORAGE



WARNING!

Before performing any maintenance or cleaning work, always ensure that the battery pack/safety key have been removed. Wait until the blade has stopped completely and the machine has cooled down.

Cleaning the product

- Use a soft brush to remove accumulated dust and debris. Wear safety glasses to protect your eyes whilst cleaning.
- Wipe down the product enclosure with a slightly damp cloth. Do not spray the unit with water. Water may destroy the switch unit and the electric motor.

Maintenance

NOTE: Always wear gardening gloves when working with sharp blades.

1. Keep all nuts, bolts and screws tight to ensure that the machine is in a safe working condition.
2. Check the grass bag frequently for wear or deterioration.
3. Examine the machine and replace worn or damaged parts for safety.

REMOVING/INSTALLING THE BLADE

1. Use the correct size wrench to uninstall the blade bolt nut.
2. Wearing heavy gloves, hold the blade still and turn the wrench anti-clockwise to remove the bolt.
3. Fit the replacement blade correctly with marks facing up and align the pegs, refit the bolt and retighten securely to torque 20N.m.



WARNING: Replace or re-sharpen the mower blade at the end of the season. Always have the mower blade re-sharpened or replaced by a recommended service centre.

Unbalanced blades will cause the lawn mower to vibrate violently, which can increase the risk of accidents occurring.

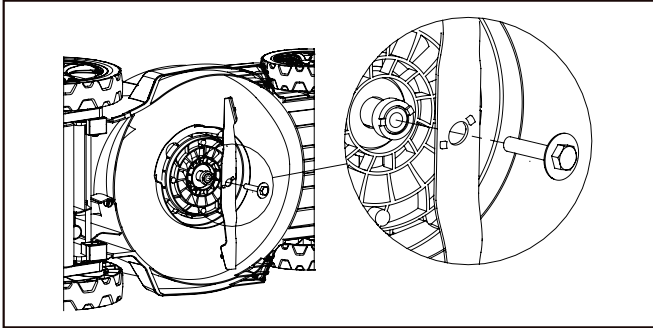

BATTERY MAINTENANCE

Use the following procedures to achieve the best battery life:

1. Protect the battery against moisture and water.
2. Store the battery only within temperature range of 5° to 45°C. Do not leave the battery in direct sunlight for extended periods of time.
3. Clean the battery regularly with a soft, clean and dry brush.
4. If you do not use the product for a long time, remember to charge and discharge the battery pack once every 6 months.

UK PLUG

If you need to replace the fitted plug, then follow the instructions below.

IMPORTANT: The wires in the mains lead are coloured in accordance with the following code:

Blue – Neutral, Brown – Live

As the colours of the wire in the mains lead of this product may not correspond with the coloured markings identifying the terminals in your plug, proceed as follows: The blue wire must be connected to the terminal marked N or coloured black. The brown wire must be connected to the terminal marked L or coloured red.

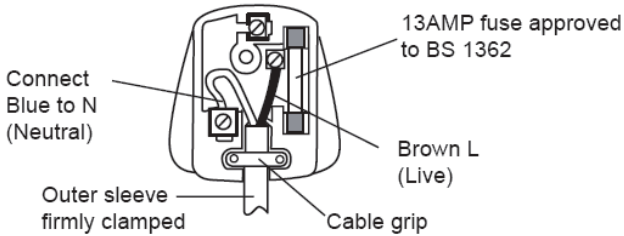

WARNING!

Never connect live or neutral wires to the earth terminal of the plug.

Only fit an approved 13 Amp BS 1363 or BS 1363/A plug and the correctly rated fuse. If in doubt, consult a qualified electrician.

STORAGE AND TRANSPORT

Storage

After cleaning the unit thoroughly, store in a cool dry place out of the reach of children.

NOTE: Remove the safety key and battery packs. Ensure cables are not trapped when folding/unfolding the handle. If stored vertically, make sure the mower is positioned in a corner so that the blade is facing inwards against a wall and the machine is secure, to prevent it falling over.

Transport

Use the original packaging whenever possible.

TROUBLESHOOTING



WARNING: Before performing any repair work, ensure that the battery pack has been removed.



WARNING: Always wear heavy-duty gloves when adjusting or cleaning, especially when handling sharp objects.

| Fault/malfunction | Cause | Remedy |
|----------------------------------|-----------------------------------|--|
| Mower fails to start | Safety key is not inserted | Insert safety key |
| | Battery is not correctly inserted | Remove the battery and reinsert |
| | Mower standing in high grass | Start motor on shorter grass or already mowed area, change cutting height if necessary |
| | The mower housing is clogged | Clean housing so that the blade can move freely |
| | Battery has no power | Check and recharge battery |
| Mower stops working /loses power | Cutting height is incorrect | Adjust the cutting height |
| | Cutting blade is worn or damaged | Replace with new blade |
| | Battery performance decreasing | Check the battery performance and charge if necessary |

| | | |
|--------------------------------------|--|---|
| Grass bag is not filled sufficiently | Cutting height is too low | Adjust cutting height |
| | The lawn / grass is wet | Allow the lawn to dry |
| | Underside of the mower deck is clogged | Clean the underside of the mower deck |
| | Cutting blade is worn or damaged | Replace cutting blade |
| Mower vibrating at higher speed | Cutting blade is unbalanced | Balance the blade by grinding each cutting edge until equal |
| | Blade is loosened /incorrectly fitted | Tighten the blade bolt |
| Mower cuts unevenly | The blade is damaged | Sharpen the blade or replace |
| | Blade is assembled incorrectly | Re-assemble blade correctly |

TECHNICAL DATA

| | |
|------------------------------|-----------------------------|
| Model no. | LM 32H |
| Voltage | 18V d.c. |
| Battery type | Lithium-ion |
| No-load speed | 3500/min |
| Cutting width | 320mm |
| Cutting height | 25-65mm |
| Capacity of grass bag | 30 litres |
| Weight | 9.5kg |
| Battery pack Model | ZDBP18014001 |
| Battery capacity | 4Ah |
| Charging time | 2.5hr |
| Battery charger Model | SMVCH001212000B |
| Input of charger | 230-240V AC, 50/60Hz 50W |
| Output of charger | 21V DC,2A |
| Protection class | □ / II |

Measured sound pressure level (L_{pA}): 87.78dB(A), K=3 dB(A)

Guaranteed sound power level: 90 dB(A)

Vibrations: 1.68 m/s² K=1.5 m/s²

The sound values have been determined according to noise test code given in EN 60335-2- 77, using the basic standards EN ISO 11201 and EN ISO 3744.

The sound intensity level for the operator may exceed 80 dB(A) and ear protection measures are necessary.

The declared vibration value has been measured in accordance with a standard test method (according to EN 60335-2-77) and may be used for comparing one product with another. The declared vibration value may also be used in a preliminary assessment of exposure.

RECYCLING AND DISPOSAL

Waste electrical products should not be disposed with household waste. Please recycle where facilities exist.

Check with your local authority or retailer for recycling advices.

GETTING HELP

Our dedicated UK-based customer helpline is open 7 days a week to assist you with assembly, parts queries and technical support. We are open during office hours but you can always send an email via **support@coreservice.co.uk**. Our experts are here to get you back enjoying your garden in no time.

For useful assembly, starting and maintenance videos, and for ordering spares, please visit **www.coreservice.co.uk**.

Using our service does not affect your statutory rights.

WARRANTY

This product is covered by a 1 year warranty.

The warranty covers any manufacturing defect in materials, workmanship and finish.

Any claim under this warranty must be made by going to your nearest Homebase store, taking your proof of purchase with you, and claims must be made within 1 year of the date of purchase.

We will offer you a free repair of the item where this is possible, or a replacement or a refund. Your statutory rights remain unaffected, in particular any rights you may have under the Consumer Rights Act 2015.

This warranty is given by HHGL Limited, MK9 1BA; HHGL (ROI) Limited, D02 X576

Please note This warranty does not apply to products misused or neglected and only covers domestic use. It does not apply to commercial use of the product.