

HOMEBASE

LUDLOW DINING TABLE

INSTRUCTION MANUAL

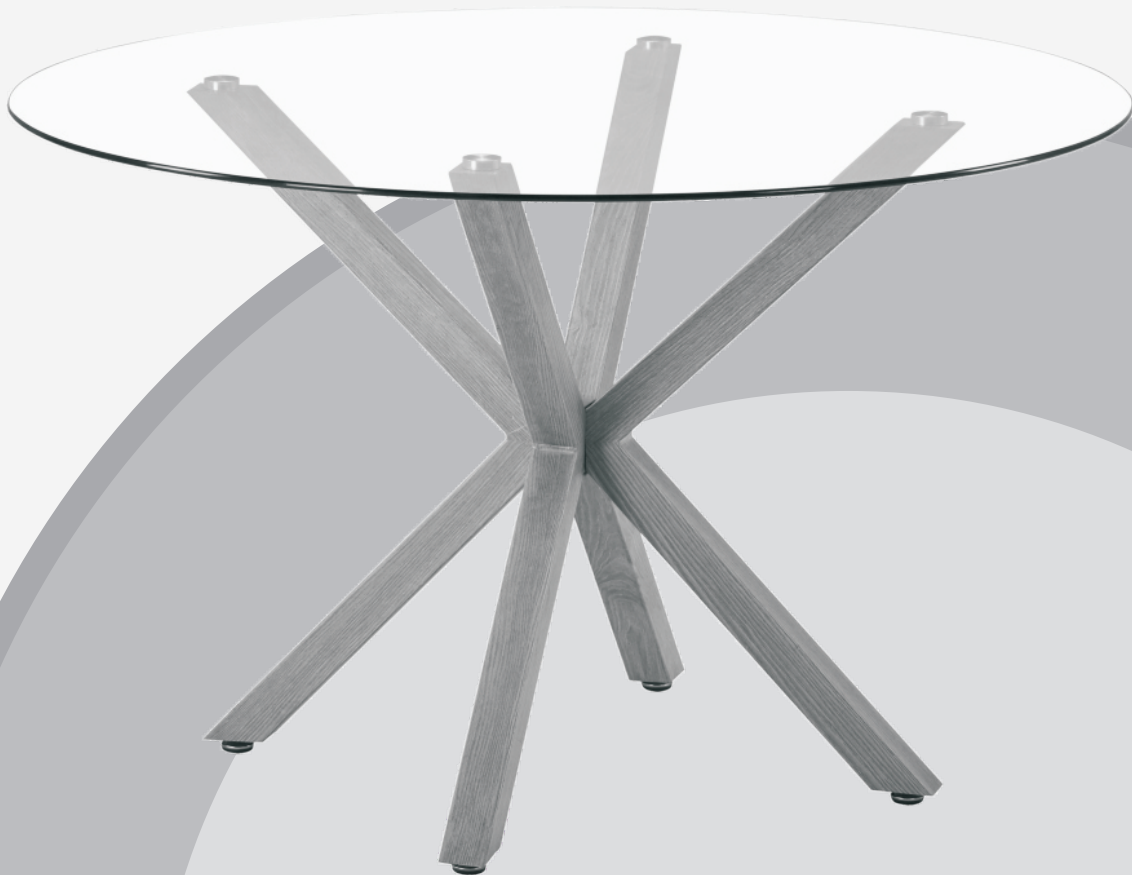

IMPORTANT: Please read these instructions before using the product and retain for future use.

HHGL Limited, MK9 1BA
HHGL (ROI) Limited, D02 X576

V1_2024

SAFETY & CARE ADVICE

Please read these instructions fully before starting assembly.

- Check you have all the components and tools listed before you start assembly.
- Remove all fitting from the plastic bags and separate them into their groups.
- Keep children and animals away from the work area; small parts could pose a choking hazard if swallowed.
- Make sure you have enough space to lay out the parts before starting.
- Do not stand or put weight on the component parts or the product, as this could cause damage.
- Assemble the item as close to its final position as possible.
- Assemble on a soft, level surface to avoid damaging the unit or floor.
- Parts of the assembly will be easier with two people.
- We do not recommend the use of power drills/drivers for inserting screws, as this could damage the unit.
- Only use hand screwdrivers.
- Dispose of all packaging carefully and responsibly.
- Domestic use only.
- Maximum safe weight of use is 60kg.

CARE AND MAINTENANCE





- Over time, the fabric can become crushed and change in appearance slightly, however, there are some simple measures you can take to preserve its softness and alluring appeal.
- For items of furniture facing heavy use, it's advisable to gently vacuum the fabric with an upholstery attachment at least once a week. Alternatively, you can also use a soft bristled brush or clothes brush. Always blot spills immediately with a clean cloth by dabbing the area gently.
- Some fabrics are prone to marking, so be mindful not to leave anything heavy resting on your furniture for too long as this can cause marks and dents.

IMPORTANT INFORMATION

- Regularly check all the bolts, screws and fastenings are secure.
- Do not use this chair unless all bolts and screws are firmly secure.
- This product should not be discarded with household waste. Take it to your local authority waste disposal centre.











COMPONENTS - CHAIR

Please check you have all the components and fittings listed below. If you find any missing or damaged parts, please contact our customer services team on 0333 003 7084 between 09:00 & 18:00, or use the contact form on our website www.homebase.co.uk

No.	DESCRIPTION	DIAGRAM	QTY
1	Table top		x 1
2	Table legs		x 4
3	Middle connection part top cover		x 1
4	Middle connection part		x 1
5	Middle connection part base cover		x 1

COMPONENTS - FITTINGS

Note: The quantities below are the correct amount to complete the assembly. In some cases, more fittings may be supplied than required.

No.	DESCRIPTION	DIAGRAM	QTY
A	Flat washers		x 4
B	Bolts 8x30x5mm		x 4
C	Bolts 8x14x5mm		x 8
D	Nut		x 1
E	Stud		x 1
F	Stickers		x 4
G	Adjustable foot caps		x 4
H	S6 key		x 1
I	S5 key		x 1
J	Spanner		x 1

STEP 1

Attach 2 x table legs (2) to middle connection part (4) using bolts (C) .
Lightly tighten with S6 key (H). Do not fully tighten at this stage.

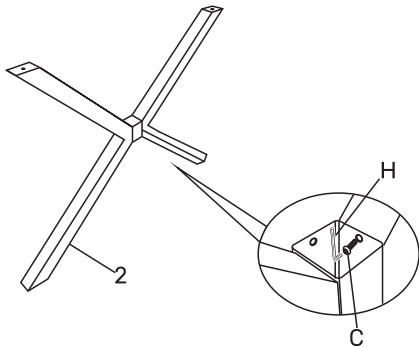

STEP 2

Attach another 2 x table legs (2) to the assembled frame built in Step 1 using bolts (C). Lightly tighten with S6 key (H).
Do not fully tighten at this stage.

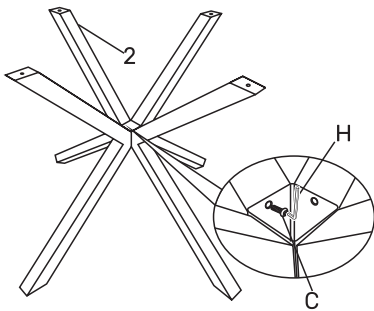

STEP 3

Place the table top (1) upside down on a clean and soft surface.
Carefully position the table leg assembled in Step 2 onto the table top (1) attaching it to the aluminium plates. Insert 4 x bolts (B) and 4 x washers (A) in each of the aluminium plates. Tighten with S5 key (I). Affix 4 x stickers (F) over the holes on each of the table legs (2). Insert 4 x adjustable foot caps (G) into the bases of the table legs (2) and tighten up by hand. Now fully tighten all bolts (C).

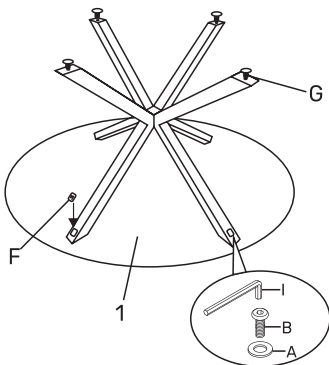

STEP 4

Tightly insert stud (E) into the middle connection part top cover (3), then insert this assembled part into the middle connection part (4).

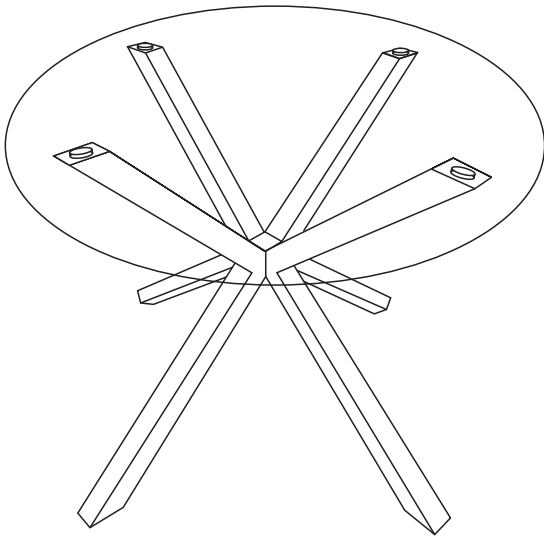
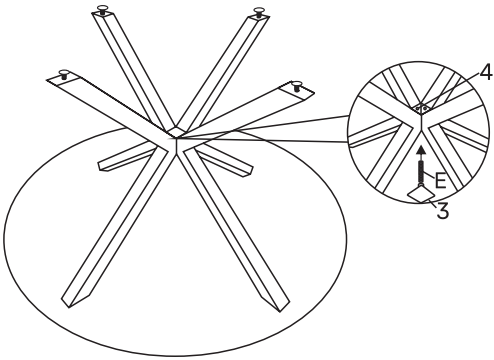

ASSEMBLY COMPLETE