

Assembled Size: 610mm High x 310mm Wide x 295mm Deep. Internal Cube Size: 285mm High x 285mm Wide x 295mm Deep

The only tools you require are an Allen key (supplied in Hardware Kit) and a small hammer

LIST OF PARTS

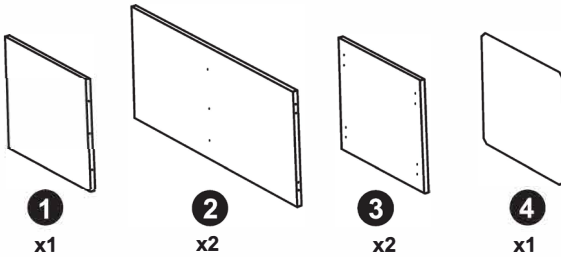

Note: All panels here are showing the internal view hole configurations.

Hardware Kit

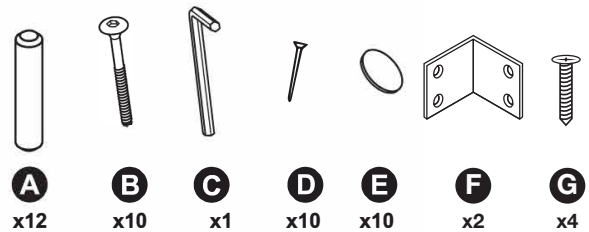

WARNING

- CHOKING HAZARD - This product contains small parts.

Hints: Assemble on a flat, clean, protected surface. Fit panels together by tapping with hand to seat in place.

STEP 1

Note: Ensure all raw edges face UP. This will be the back of the unit.

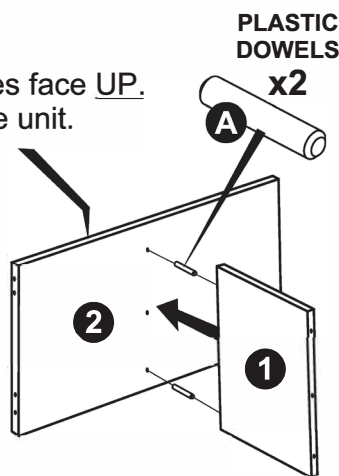

STEP 2

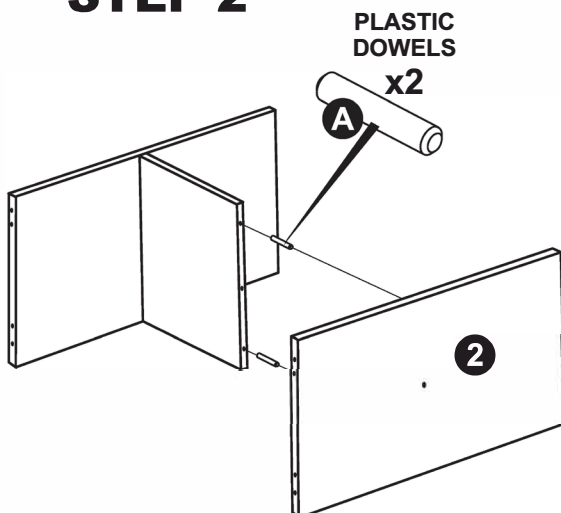

STEP 3

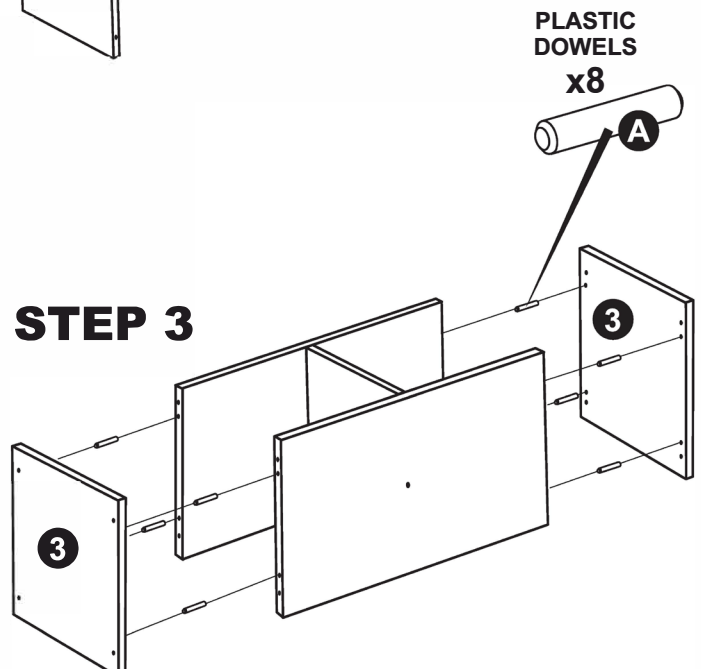

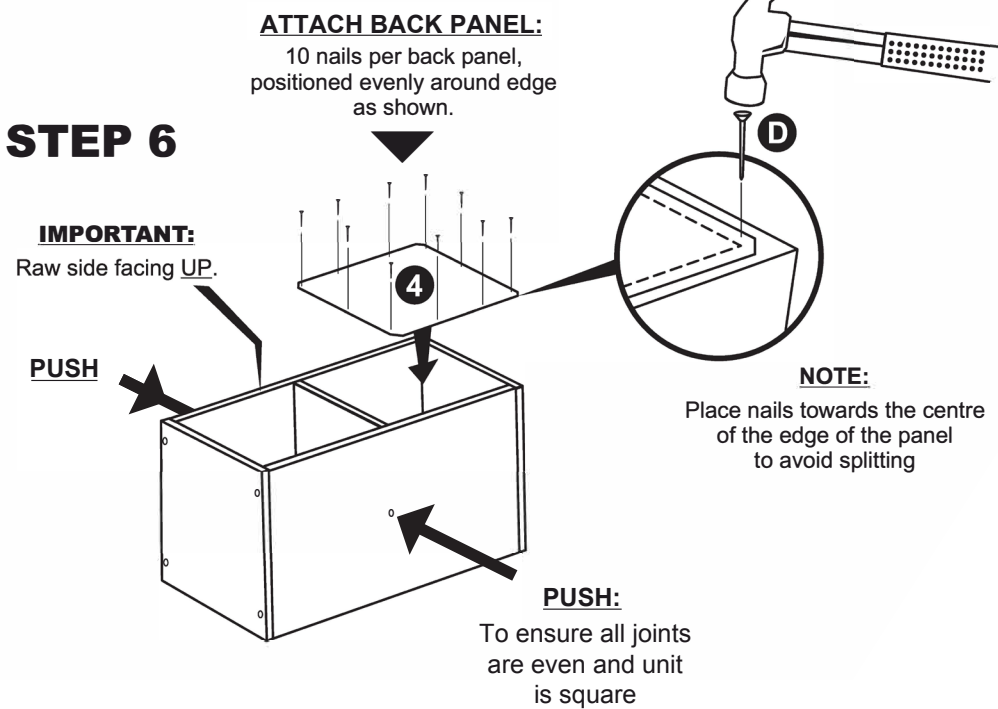
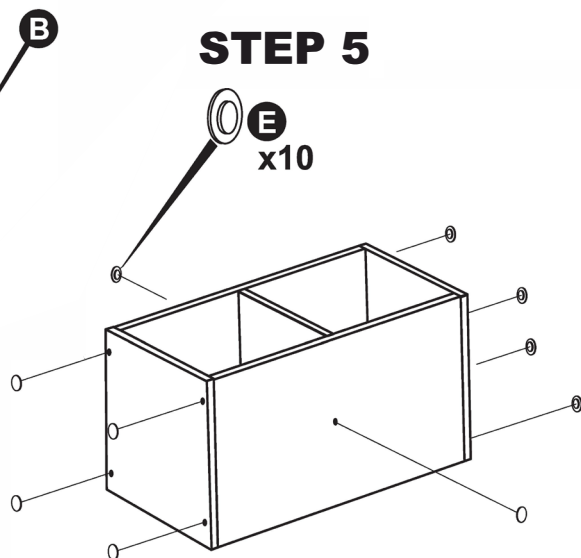
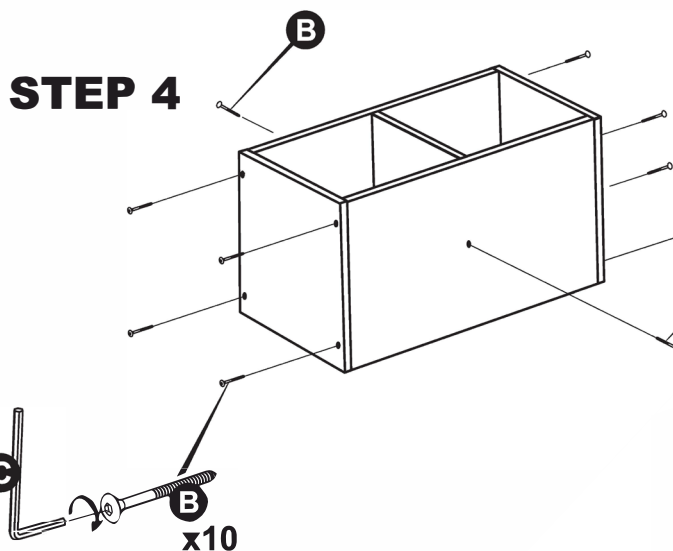

WARNING: TO AVOID THE RISK OF STORAGE TIPPING OVER, PLEASE ATTACH WALL MOUNT SUPPLIED TO THE PRODUCT AND WALL AS SHOWN.

As wall materials vary, screws for fixing to wall are not included. For advice on suitable screw system, contact your local dealer.

